

LA-9445-PNTX-J

Los Alamos National Laboratory is operated by the University of California for the United States Department of Energy under contract W-7405-ENG-36

*Supplementary Documentation for an
Environmental Impact Statement
Regarding the Pantex Plant*

Socioeconomic Assessment

LOS ALAMOS NATIONAL LABORATORY
3 9338 00308 0784

This report was prepared by Kathy Derouin, Lois Schneider, and Mary Lou Keigher, Group H-8.

DISCLAIMER

This report was prepared as an account of work sponsored by an agency of the United States Government. Neither the United States Government nor any agency thereof, nor any of their employees, makes any warranty, express or implied, or assumes any legal liability or responsibility for the accuracy, completeness, or usefulness of any information, apparatus, product, or process disclosed, or represents that its use would not infringe privately owned rights. References herein to any specific commercial product, process, or service by trade name, trademark, manufacturer, or otherwise, does not necessarily constitute or imply its endorsement, recommendation, or favoring by the United States Government or any agency thereof. The views and opinions of authors expressed herein do not necessarily state or reflect those of the United States Government or any agency thereof.

LA-9445-PNTX-J

Issued: December 1982

Supplementary Documentation for an Environmental Impact Statement Regarding the Pantex Plant

Socioeconomic Assessment

D. A. Rapp*

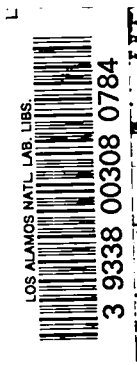

*Consultant at Los Alamos. 8730 West Mountain View Lane, Littleton, CO 80125.

Los Alamos Los Alamos National Laboratory
Los Alamos, New Mexico 87545

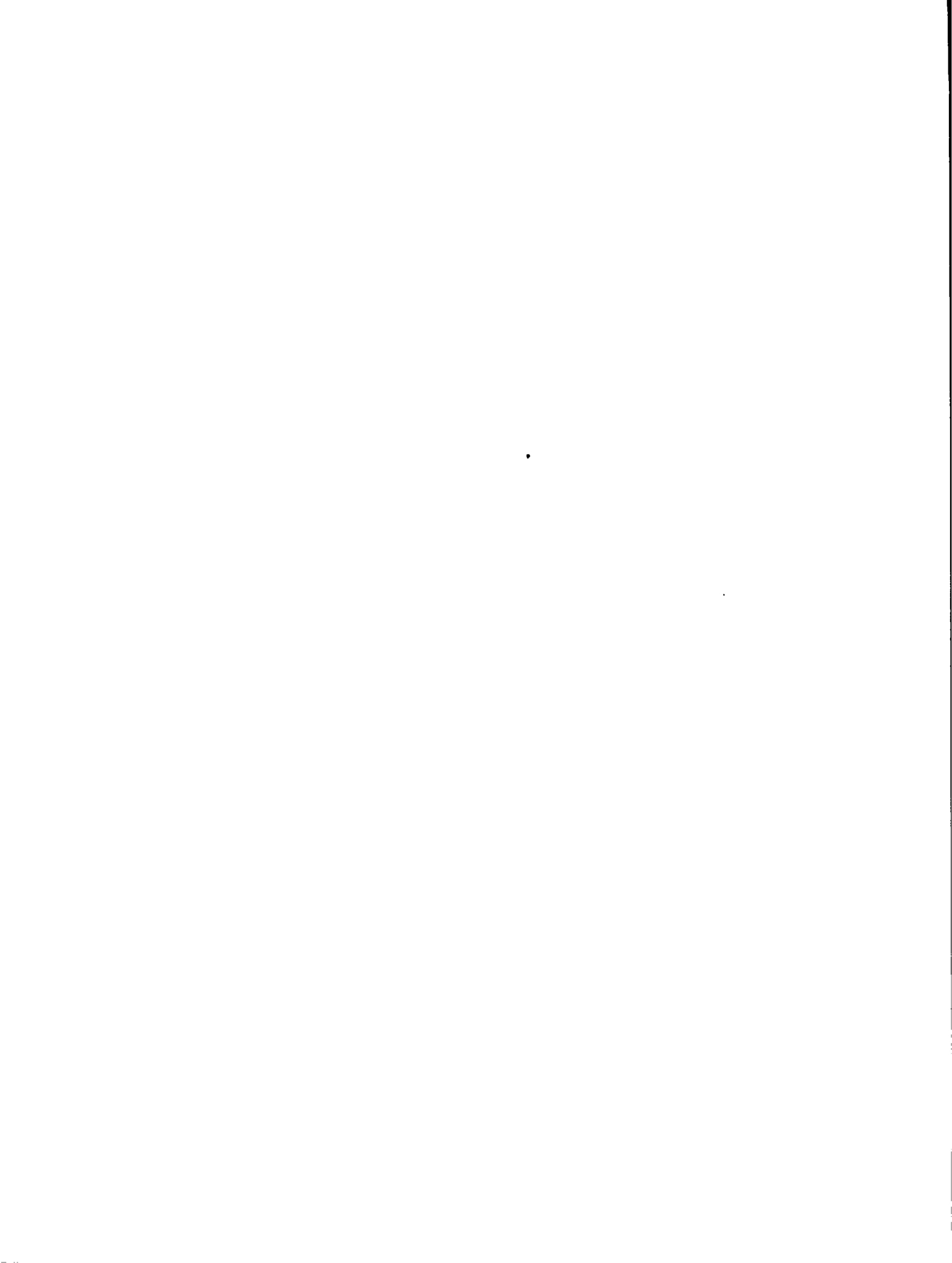

CONTENTS

ABSTRACT

I.	INTRODUCTION	1
	A. Summary	2
	B. Methodology	2
II.	PANTEX PLANT	5
	A. General Description of the Area	5
	B. Current Population and Employment	6
	C. Potential Change in Population and Employment	7
	1. Option 1--New Construction	7
	2. Option 2--Major Upgrade	7
	3. Option 3--Major Replacement	8
	4. Option 4--No Action	9
	5. Termination	9
	D. Current Economic Condition	10
	E. Projected Economic Change	10
	F. Community Resources	11
	1. Housing	11
	2. Utilities	11
	3. Education	13
	4. Health Services	14
	5. Public Safety	14
	6. Transportation	14
	7. Quality of Life--Cultural Resources	15
	8. Land Use	15
III.	IOWA ARMY AMMUNITION PLANT	15
	A. General Description of the Area	15
	B. Current Population and Employment	16
	C. Potential Change in Population and Employment	17
	1. Option 1--Partial Relocation	18
	2. Option 2--All-New Plant	18
	D. Current Economic Conditions	19
	E. Projected Economic Change	20
	1. Option 1--Partial Relocation	20
	2. Option 2--All-New Plant	20

F. Community Resources	21
1. Housing	21
2. Utilities	21
3. Education	22
4. Health Services	22
5. Public Safety	23
6. Transportation	23
7. Quality of Life--Cultural Resources	23
8. Land Use	24
IV. HANFORD SITE	24
A. General Description of the Area	24
B. Current Population and Employment	25
C. Potential Change in Population and Employment	26
Option 1--All-New Plant	26
D. Current Economic Conditions	27
E. Projected Economic Change	27
F. Community Resources	27
1. Housing	27
2. Utilities	28
3. Education	28
4. Health Services	29
5. Public Safety	29
6. Transportation	29
7. Quality of Life	30
8. Land Use	30
ACKNOWLEDGMENTS	30
APPENDIX A--METHODOLOGY	31
APPENDIX B--PANTEX PLANT	43
APPENDIX C--IOWA ARMY AMMUNITION PLANT	65
APPENDIX D--HANFORD SITE	87
REFERENCES	93

SUPPLEMENTARY DOCUMENTATION FOR AN ENVIRONMENTAL IMPACT STATEMENT
REGARDING THE PANTEX PLANT:

SOCIOECONOMIC ASSESSMENT

by

D. A. Rapp

ABSTRACT

This report documents work performed in support of preparation of an Environmental Impact Statement regarding the Department of Energy's Pantex Plant near Amarillo, Texas. The report addresses the socioeconomic tradeoffs associated with several different construction proposals at the Pantex Plant and at alternative locations in Iowa and Washington. The socioeconomic assessment provides the basis for comparison of impacts, if any, on the population of an area, its economy, governmental infrastructure, and various measures of quality of life. The economic implications of each proposed action have been described in terms of their potential effects on the local payrolls and retail sales within a geographical trade area.

I. INTRODUCTION

This report documents work performed in support of preparation of an Environmental Impact Statement (EIS) regarding the Department of Energy's Pantex Plant near Amarillo, Texas. This EIS addresses continuing nuclear weapons operations at the Pantex Plant and the construction of additional facilities to house those operations. The EIS was prepared in accordance with current regulations under the National Environmental Policy Act. Regulations of the Council on Environmental Quality (40 CFR 1500) require agencies to prepare concise EISs with less than 300 pages for complex projects. This report was prepared by Los Alamos National Laboratory to document details of work performed and to present supplementary information considered during preparation of the Draft EIS.

The socioeconomic assessment considers several measures of the quality of life associated with construction alternatives proposed for continued nuclear

weapons operations by the Department of Energy (Schnurr 1982B). In addition to an assessment of the construction scenarios, there are assessments of the no action and the termination alternatives at the Pantex Plant. No action implies business as usual with no increases in present production capacity, whereas termination at the Pantex Plant would occur only with total relocation of weapons production facilities.

Relocation of the weapon production facilities considers the socioeconomic impacts of moving some or all of the Pantex Plant operations to existing facilities (which would require refurbishing) or to new facilities at a formerly used nuclear weapons assembly plant site near Burlington, Iowa, or of relocating all of the Pantex Plant operations to new facilities to be constructed at the Hanford Site near Richland, Washington (Schnurr 1982B).

The socioeconomic analysis assesses the effects of various projections of work force requirements, population changes resulting from an in-migration of workers, demand for additional housing, and the demand placed on public facilities and services. In addition, the projected new payroll associated with both construction and operational employment is compared to current total effective buying income and changes in retail sales.

The assessment of the economic impacts on local retail sales enables the businessman on Main Street and the potentially affected citizen to better evaluate the economic tradeoffs between alternative actions. Precision in the assessment of potential change in retail sales is virtually impossible. However, by using the same basic data source for the analysis of each alternative, it is possible to provide a reasonable comparison between actions.

A. Summary

The study found that construction activities would produce valuable new payrolls with little, if any, negative socioeconomic impacts. This lack of negative effects is largely attributed to the large resident labor supply at each location. However, permanent relocation of the Pantex Plant to another state would cause significant economic hardship for the Amarillo trade area.

Similarly, the study found that a permanent operating work force was available locally at all three locations.

B. Methodology

Socioeconomic impacts of a project generally arise from the in-migration of workers to take jobs not filled by local residents. The large or rapid influx of workers contributes to such problems as crowded schools, inflated housing prices, and inadequate health services.

This study adopts a key assumption that is based on other socioeconomic studies conducted in western states during the past 10 years by Gilmore (1975). The assumption is, if temporary growth within a local community is less than 5% per year for several consecutive years or less than 10% per year in any year, then few, if any, unmanageable impacts develop. It should also be recognized that the large population base now in place at each location significantly increases the assimilative capacity of the communities (SEAM 1978 and Rapp 1974). Given this assumption, the principal focus of the socioeconomic assessment is to project in-migration and consequent changes in population, school enrollment, and so forth. This study employs two projection methods: a qualitative evaluation of the adequacy of the existing resident labor force and a quantitative, worst case projection of in-migration and population changes.

The qualitative evaluation was based on appraisals of construction trade groups, planning authorities, and most importantly, state employment agencies. Without exception, the official state employment agencies have indicated they foresee no shortages in the local labor supply that may be required for the construction and operation of a weapons plant at any of the three locations (see letters and related documentation in Appendices B, C, and D).

The quantitative, worst case analysis considers the socioeconomic impacts of in-migration of 1500 construction workers (basic workers) and over 600 nonbasic workers (service workers), plus their families. The proposed action with the greatest labor requirements is major plant replacement (Pantex Plant Option 3). Fifteen hundred basic workers represent over 90% of the peak construction labor requirement at Amarillo and 80% of the peak requirements at Burlington and Hanford.*

Given a worst case forecast of in-migrant workers, the analysis proceeds with forecasts of in-migrant population. Figures 1 and 2 illustrate the sequence of calculations. Figure 3 presents an economic model used to forecast changes in income and retail sales. Appendix A provides documentation of the forecasts and underlying assumptions. Clarification of the employment multipliers used in this study is necessary: a multiplier of 1.68 is used to estimate total employment during the construction period. That is, every direct new construction job induces 0.68 indirect jobs. By contrast, total employment during the operational phase uses a multiplier of 2.0. That is, every direct operational job induces 1.0 additional jobs in the trade area. The difference in the multiplier reflects growth in the service area as employment stabilizes following construction (Rapp 1980 and DRI-BBC 1982).

Generally, the forecasts at each site were presented by multicounty trade areas or Standard Metropolitan Statistical Areas (SMSAs). The trade areas, for all practical purposes, reflect the commuting ranges of workers employed at the

*The difference occurs because certain facilities at the Pantex Plant (Amarillo) would not be rebuilt, thus a smaller work force requirement.

Total man-year	÷	Construction time	=	Average man-years per year
Average man-years per year	x	130% to 150%	=	Peak year basic jobs
Peak year basic jobs	x	1.68	=	Total employment
Total employment	-	Peak year basic jobs	=	Nonbasic employment

Fig. 1. Construction work force forecasting model.

Peak year in-migrant workers	x	65% married workers	=	Total married workers
Peak year in-migrant workers	x	35% single workers	=	Total single workers
Peak year in-migrant workers	x	Average 2.75 person per household	=	Total new population
Total new population	-	Single workers	=	Total married workers
Total married workers	x	0.7 students per household	=	Total new students

Fig. 2. Construction work force in-migration employment and population model.

Basic work force	x	Basic annual salary	=	Total basic payroll	
Nonbasic work force	x	Nonbasic annual salary	=	Total nonbasic payroll	
Total basic payroll	+	Total nonbasic payroll	=	Combined payroll	
Combined payroll	x	80%	=	Total effective buying income	
Total effective buying income	x	Total retail sales in area	÷	Total effective buying income in area	= Total new retail sales in area
Total new retail sales in area	÷	Total retail sales in area	=	% increase over current retail sales	

Fig. 3. Construction work force economic forecasting model.

three alternative sites. The trade area definitions were proposed by regional planning organizations in cooperation with state agencies.

II. PANTEX PLANT

A. General Description of the Area

The Amarillo trade area includes portions of 11 counties in the Panhandle Region of North Texas. These are Potter and Randall Counties that, with the city of Amarillo, comprise the Amarillo SMSA. Also included in the trade area are Armstrong, Carson, Castro, Deaf Smith, Hartley, Hutchinson, Moore, Oldham, and Swisher Counties (Amarillo 1980). Distances between Amarillo and major cities in the western states show the relative isolation of the Amarillo metropolitan area. To the east, Dallas is 361 mi and Oklahoma City is 264 mi. Albuquerque is 286 mi to the west and Denver is 423 mi to the northwest. San Antonio is approximately 520 mi to the south.

Amarillo is surrounded by 6.5 million acres of irrigated farmland that supports an agriculturally oriented industry. In addition, there is oil and gas production with an associated petrochemical industry. The Pantex Plant located in Carson County is approximately 17 mi northeast of the center of Amarillo.

The Pantex Plant represents just one dimension to a highly diversified economic base in the 11-county Amarillo trade area.

The Pantex Plant site encompasses 9100 acres or over 14 square mi of nearly flat prairie land. In addition to buildings and roads, land use within the Plant boundaries includes large tracts of cropland and pastures (Appendix B, Item 3). Almost all the land is cropland beyond the Plant boundaries--both dryland and irrigated farmland interrupted only by a few rural roadways and an occasional farmstead. The average farm size in Carson County is approximately 1280 acres or 2 square mi (Smith 1981). As a result, the settlement pattern within a 5-mi belt around the Plant site averages about two persons per square mile. Greater population densities occur south and west of the Plant in the direction of Amarillo. Approximately 5 mi from the main Pantex Plant operations area is the Texas Tech Agriculture Research Station. Somewhat farther are the Iowa Beef Packers facilities, and about 7.5 mi is the industrial park adjoining the Amarillo International Airport. The community of Panhandle (1980 population 2226) is located 10 mi due east of the Plant. The city of Borger, with a population of nearly 16 000, is located approximately 20 mi north-northeast of the Plant. The town of Panhandle is totally surrounded by irrigated cropland, whereas Borger is situated in rolling rangeland near Lake Meredith on the Canadian River.

B. Current Population and Employment

The 1980 US census of population reported a total of 276 342 residents in the 11-county Amarillo trade area. The economic and social focal point of the entire region is metropolitan Amarillo with over 176 000* residents residing in the SMSA (Potter and Randall Counties).

Pantex employs approximately 2.7% of the average 1981-82 labor force (87 600) in the Amarillo SMSA as reported by the Texas Employment Commission (Appendix B, Item 4). The Pantex Plant is the second largest employer in the Amarillo SMSA, exceeded only by the Amarillo public school system. In 1981, Mason and Hanger--Silas Mason Company, Inc., estimated an average of 2371 employees (Appendix B, Item 1). The composition of the work force is approximately 80% male and 20% female.**

Mason and Hanger reported that 87% of the Pantex Plant employees reside in the Amarillo metropolitan area. It should be noted that place of residence was

*Appendix A, Item 17, provides estimates of 1981 population representing growth since the 1980 US census count.

**Descriptive information about employee composition and their families, commuting patterns, etc., were supplied in an interview with M. L. Ott, George Curtis, Odie Hood, and Earl Rhodes, Mason and Hanger-Silas Mason Company, Inc., February 3, 1981.

determined by postal zip code, and thus a large number of workers may live in nearby rural areas. The next largest group, 6.9%, resides in Carson County (where the Pantex Plant is located) primarily in the town of Panhandle, the county seat. Hutchinson County (Borger: population 15 837), Randall County (Canyon: population 10 724), and Armstrong County (Claude: population 1112) attract 1.5 to 2.5% of the total Pantex Plant work force. The balance of the work force (less than 2%) resides in Oldham, Gray, and Donley Counties (Appendix B, Item 2).

The Amarillo SMSA has the third lowest unemployment rate in the state, ranging from 3.4% in 1979 to about 5.5% in 1982. In September 1982 there were 4900 people unemployed in the area.* Such data give credence to the letters from the Texas Employment Commission and the Texas Panhandle Builders Association (Appendix B, Items 4 and 5). These letters and the experience of the agency provide the basis for the determination that virtually all construction work force requirements can be supplied locally.

C. Potential Change in Population and Employment

As previously noted in Section I, this analysis considers several construction options at the Pantex Plant site near Amarillo. A summary of the changes expected with each option is in Table I and is supported in full detail in Appendix A, Items 11 and 13.

Because all construction options are projected to generate only small changes in population, the community analysis examines in detail only construction Option 3, which has the greatest potential for change in population. The following subsections explain the potential employment and population changes associated with each proposed construction option presented in Table I.

1. Option 1--New Construction. Proposed construction under Option 1 would occur over a period of about 7 years. The level of activity at any time would not require more than an estimated 459 construction workers. Induced employment would add another 312 jobs. The combined total new jobs could be filled by the available labor supply in the labor force area (see Appendix B, Items 4 and 5).

2. Option 2--Major Upgrade. The proposed construction time for this option was given as 6 years. However, to provide a range of possible labor force requirements, the study projected a 5-year and an 8-year construction time frame. As noted in Appendix A, Item 1, peak construction work force levels for the 5-year scenario will rise to 150% above the average employment level projected for the full construction period and 130% for the 8-year scenario. The peak period is expected to occur 24 to 36 months after the start of construction. At its peak, total employment for this option is projected to

*Jeff Auld, Texas Employment Commission, telephone interview, October 1982.

TABLE I
 PANTEX PLANT OPTIONS
 POTENTIAL CHANGES IN POPULATION AND EMPLOYMENT

<u>Option</u>	<u>Basic Jobs</u>	<u>Nonbasic Jobs</u>	<u>Hypothetical Population Change (Construction)</u>	<u>Permanent New Operating Jobs</u>
<u>Option 1</u> New construc- tion	459	312	0	200
<u>Option 2</u> Major upgrade	1000	680	0	200
<u>Option 3</u> Major replacement	1600	1088	5808	200
<u>Option 4</u> No action	217	148	0	0

reach 1680 basic and induced jobs. According to the Texas Employment Commission and others, the projected work force level is not expected to require an in-migration of workers.

3. Option 3--Major Replacement. The given construction time for total replacement of the existing plant is 7 to 8 years. For purposes of establishing a worst case scenario, the analysis considered a 5- and 8-year construction period. Thus, a range of possible impacts can be considered.

Basic employment in the 5-year scenario is expected to peak at 1600 workers, which is 150% above the average work force. In the 8-year scenario, peak employment would continue for a longer construction period, thus requiring fewer workers at any time to accomplish the same activity. Consequently, peak employment in the 8-year scenario is calculated to rise to 1224 construction workers, which is 130% of the average employment level. Combined basic and nonbasic employment during the peak period of the 5-year scenario is expected to generate 2688 jobs. As detailed in Appendix A, Items 11 and 13, 40% of the nonbasic jobs would be expected to be filled by local residents (housewives, students, etc.). Therefore, the number of jobs to be filled by in-migrant workers in both basic and nonbasic jobs is 2112.

4. Option 4--No Action. The no-action option for this EIS represents continued operations at present levels with no new construction except those projects already under construction by the end of 1982. This option will have no socioeconomic impacts because it involves only 365 basic and nonbasic jobs, and the construction activity associated with the Pantex Plant Option 4 is presently taking place. Therefore, even in the event of partial transfer of the Pantex Plant operations to the Iowa Army Ammunition Plant (IAAP), which is discussed in Section III, this Option 4 construction activity will continue.

5. Termination. Termination of current operations at the Pantex Plant would occur if all operations were relocated to Iowa or Washington. Closing the plant would eliminate about 2400 basic jobs, but it could mean the loss of many additional nonbasic jobs in the Amarillo trade area (as happened when the Amarillo Air Force Base closed).

The Texas Industrial Commission (TIC) projects that over 8000 nonbasic jobs would be lost statewide (Appendix B, Item 7). Although the TIC figure seems high based on experience (Rapp 1980 and DRI-BBC 1982), it should be noted that the Amarillo area imports most of its fabrication material and manufactured goods. Therefore, the detailed projections of statewide impacts reported by the TIC may be correct.

In general, basic employment is projected to produce 1 to 1-1/2 nonbasic jobs in the immediate service area and somewhat more statewide. A number of studies conducted in western states project secondary employment multipliers (nonbasic employment) to range from a low of 0.45 to 2.2 per basic job (Rapp 1980, see also Appendix A, Item 16). After consultation with staff members at the TIC,* an employment multiplier of 2.0 was used in the EIS (each permanent basic job generates one nonbasic job in the Amarillo trade area).

Using a multiplier of 2.0, the study projects a loss of 4800 jobs in the Amarillo trade area with the termination of Pantex Plant operations. The loss of 4800 jobs represents 5.5% of the 1981 estimated civilian labor force (87 600) reported for the Amarillo SMSA (Appendix B, Item 4). The percentage figure would be somewhat smaller (4.7%) if the total labor force in all 11 counties was considered (LATA 1982).

Because termination at the Pantex Plant would occur with simultaneous relocation of the Plant operation to another state, it is possible that many permanent operating personnel could transfer with the operation. However, no estimate of the number of workers and families that may be willing to transfer has been made.** Very likely, many Pantex Plant workers would choose retirement

*Al Glasscock and Don Dawkins, Texas Department of Water Resources, and Chuck Newell of the TIC, telephone conversations, October 1982. See also Appendix A, Item 17.

**Closing of similar production facilities in Iowa in 1975 resulted in an extremely small number of worker transfers to the Pantex Plant.

or seek other employment to remain in the Amarillo area. Yet, depending on employment opportunities in the Amarillo area, younger families may be forced to follow their jobs.

D. Current Economic Condition

The economic data source used at all three geographic locations is the "1982 Survey of Buying Power," published in Sales and Marketing Management, a national sales journal (S&MM 1982). The S&MM data source has been used by the Amarillo Chamber of Commerce and was also recommended by the Iowa Department of Revenue, Division of Research and Statistics. It provides a uniform basis for comparison at all three locations. (See Appendix A, Item 17, for a summary of the statistical data.)

The S&MM data source reported that the 1981 effective buying income of all residents in the 11-county Amarillo trade area totaled \$2 727.182 million and retail sales totaled \$1 759.497 million. (Effective buying income is defined in this EIS as the total income reported in an area, less 20% for personal taxes and nontax payments for community services.) The ratio of retail sales to effective buying income is 64.5%. This ratio provides a basis for estimating the contribution new construction and operating payrolls make to retail sales in a trade area. [A similar methodology was followed in the analyses of other locations examined in the EIS (Appendix A, Item 10).]

The total 1981 payroll at the Pantex Plant was reported at \$54.4 million, plus another \$3.5 million in local purchases of supplies and services. Pantex Plant management also reported the Amarillo public schools and surrounding school systems serving Pantex employees received about \$65 000* per year in Federal impact funds. In addition, the study has projected nonbasic employment to generate approximately \$48.4 million per year.

The sum of the annual payrolls and purchases totals approximately \$106.4 million. The study then calculated that a division of the gross dollars results in \$21.2 million in taxes, \$85.12 million in effective buying income, and \$54.9 million in retail sales in the Amarillo trade area (Appendix A, Item 12). By contrast, the TIC projects the \$54.4 million Pantex Plant payroll generated over \$58.4 million in taxes alone (larger than the original payroll) and adds over \$1 billion to the statewide economy (Appendix B, Item 7).

E. Projected Economic Change

Economic impacts associated with alternative actions are reflected in both basic and nonbasic payrolls. Basic payrolls are generated by the construction work force, and nonbasic payrolls are generated in the business community. The

*M. L. Ott et al., Mason and Hanger-Silas Mason Company, Inc., personal interview, reported \$56 500 to Amarillo public schools and a total of \$8 500 to other school systems serving Pantex Plant employees, February 3, 1981.

buying income determines the expected contribution that new payrolls will make to retail sales in a trade area.

Table II presents a summary of the estimated contribution of each construction option to the economy of the Amarillo trade area. A complete description of the calculations is presented in Appendix A, Item 11.

F. Community Resources

The analysis of community resources considers only those facilities and services likely to be affected by the hypothetical worst case scenario (Pantex Plant Option 3 with about 2100 workers). In the course of field visits to the Amarillo area, local officials suggested community resources that should be evaluated. These resources are housing, utilities, schools, health services, public safety, transportation, cultural resources, and land use. Documentation used in the evaluation is presented in Appendix B. The assessment of the Pantex Plant Option 3 is as follows.

1. Housing. Demand for housing in the Amarillo area has been satisfied since the closing of the Amarillo Air Force Base in the late 1960s. However, major expansion of the population over a short period of time may result in some temporary shortages (Amarillo 1980).

In early 1982, there were many homes on the market; however, this may reflect the high cost of financing. Therefore, a shortage of affordable housing could occur in Amarillo before mobile home park construction catches up to demand. In the worst case scenario during the peak construction period, the Amarillo trade area would gain 5808 new residents [an estimated 739 single workers and 5069 persons (1373 families)] or about 2.1% of the population in the 11-county trade area. Typically, about 50% of migrant construction workers bring their mobile homes; the balance rent or buy housing. Approximately 90% of the migrant work force and family members (5227 total) are expected to locate in the Amarillo SMSA. This will increase the population of the SMSA about 2.9% above the 1980 US census count. The balance of the work force and families would probably locate in rural areas or in Borger, Panhandle, or perhaps White Deer. At Panhandle, the lack of new housing will require that virtually all new growth be accommodated in worker-owned mobile homes (Appendix B, Item 5).

2. Utilities. Natural gas is supplied to the Amarillo area and the Pantex Plant by the Pioneer Corporation and their operating company, Westar Transmission. The large Westar system provides gas to a 30 000-square-mi service area in West Texas. The Pioneer Corporation (PC) and its subsidiary divisions report a reserve life index of 11.7 years of assured supplies, which is considerably higher than most companies.* Electrical power is supplied by the Southwestern Public Service Company (SPC) with corporate headquarters in

*Harold Well, Vice President of Westar, telephone interview, June 1982.

TABLE II

POTENTIAL ECONOMIC CHANGES FOR PANTEX PLANT CONSTRUCTION OPTIONS*

<u>Option</u>	<u>Basic Jobs</u>	<u>Induced Jobs</u>	<u>Total Peak Year Payroll in Dollars (millions)</u>	<u>Per Cent Increase in Retail Sales</u>	<u>Permanent New Jobs</u>	<u>Permanent New Payroll in Dollars (millions)</u>	<u>Per Cent Increase in Retail Sales</u>
<u>Option 1</u> New construction	459	312	18.4	0.54	200	8.68	0.3
<u>Option 2</u> Major upgrade	1000	680	34.0 - 40.0	1.0 - 1.2	200	8.68	0.3
<u>Option 3</u> Major replace- ment	1600	1088	49.0 - 64.0	1.4 - 1.9	200	8.68	0.3
<u>Option 4</u> No action	217	148	8.67	0.3	0	0	0
<u>Pantex</u> Partial reloca- tion (IAAP Option 1)	217	148	8.67	0.3	100**	4.34	0.1

* Source: Appendix A, Item 11.

**Permanent jobs added only in the event of partial relocation to IAAP.

Amarillo. The company is an investor-owned electric utility serving a population of over 1 million in a 45 000-square-mi area of the Panhandle and the south plains of Texas, eastern and southeastern New Mexico, the Oklahoma Panhandle, and southwestern Kansas. The interconnect system consists of 10 principal power plants including 41 generating units with a total capacity of 3660 megawatts. Uninterrupted power supplies are assured with major interconnections with members of the Southwest Power Pool and electric utility systems in New Mexico, Oklahoma, and Kansas.*

Approximately 58% of the Amarillo municipally owned water is supplied from surface water sources. The balance of the need is supplied by 103 deep fresh water wells. The Pantex Plant water requirements are supplied by five deep water wells (Purtymun 1982B).

No shortage in utility services is projected with any proposed construction and operating activity at the Pantex Plant (Amarillo 1980).**

3. Education. The Amarillo Independent School District (AISD) operates 31 elementary schools, 8 junior high schools, 4 high schools, and 3 special education schools. The total enrollment in AISD at the end of the 1981-82 school year was 26 367 students. The 898 children of Pantex Plant employees represent about 3.4% of all students in the district. In addition, school systems in surrounding counties provide services to an estimated 180 children of Pantex Plant workers.

Institutions of higher education in the immediate area include Amarillo College with 8498 students in the 1980 degree program and 15 187 in special programs. The West Texas State University at nearby Canyon had a 1980 enrollment of 6700 students.

In the worst case scenario, 865 additional students are projected for the AISD. This represents an increase of 3.4% over the 1981-1982 enrollment (Appendix A, Item 13D). At Panhandle, younger families with few children of school age are expected if mobile home space can be found. The extreme-case scenario places an estimated 25 to 30 children of school age in the community. This represents a 4.4% increase over the 1981-1982 enrollment of 687 in the Panhandle Independent School District.

During the peak construction period, another 65 to 70 children from construction workers' families are expected to be enrolled in still other school districts within the commuting area of the Pantex Plant. No adverse impacts are expected within the educational systems serving Pantex Plant employees.

*J. S. Bosarge, Southwestern Public Service Company, telephone interview, June 1982.

**Don Renner, Assistant Manager of Amarillo Chamber of Commerce, telephone interview, December 1981.

4. Health Services. Amarillo provides a full range of health services and medical care. Hospitals in the metropolitan area presently provide about 5 beds/1000 residents compared to Federal guidelines that recommend 4 beds/1000. The Texas Health Manpower Reports for Physicians in 1981 provide a detailed summary of the ratio of population to licensed physicians, to direct-patient-care physicians, and to direct-care/primary-care physicians for the Amarillo metropolitan area, nonmetropolitan area, and the entire 25-county area served by the Panhandle Health Systems Agency (PRPC 1981). The ratio ranges from a low of one doctor/583 population in the metropolitan area to a high of one doctor/2419 population in the rural area. The average for the health service area is one doctor/2067 population, which is very close to the desired ratio of 1/2000 recommended by the American Academy of Family Practice and well above the Federal guidelines of 1/3000 in designated manpower shortage areas (Appendix B, Item 6).

5. Public Safety. The Amarillo SMSA is protected with the full range of public safety services expected in a thriving community of nearly 176 000. For example, as of 1980, there was one sworn officer/645 residents and one fireman/730 residents.* The Potter County Sheriff's Department reported a total of 104 sworn deputies, and the Randall County Sheriff's Department reported 32 sworn officers. Both sheriffs' departments considered their authorized strength adequate for the present needs.**

Under Option 3, the temporary increase could require the City of Amarillo to employ about six additional police officers and six firemen to maintain the present ratio of public safety employees per capita. The Potter County Sheriff's Department may need to add one or two deputies to maintain a similar balance in rural areas.

6. Transportation. The Amarillo area is served by Interstate Highway 40 and five other US highways. Eighteen motor freight companies, four intercity bus lines, and three railroad companies serve the area. In addition, seven airlines operate at the Amarillo International Airport. The airport can handle all large military aircraft (Amarillo 1979).

In the worst case scenario, doubling of the Plant work force may increase commuter traffic beyond acceptable safety standards on US Highway 160 (a four-lane divided highway). In that event, additional law enforcement and highway construction may be required at several intersections and at railroad crossings near the Pantex Plant.

*Colonel Hollis, Amarillo Police Department, telephone interview, June 15, 1982.

**Captain Crump, Potter County Sheriff's Office, and Chief Deputy R. N. McDonald, Randall County Sheriff's Office, telephone interviews, June 16, 1982.

7. Quality of Life--Cultural Resources. The Amarillo area supports a full range of cultural activities and recreational facilities. These include the Amarillo Symphony, dinner theaters, dance companies, art centers, rodeos, Texas League baseball, college sports, and parks and recreational areas. The City maintains 52 public parks, and their youth programs have the largest number of baseball parks in the US (Amarillo 1980).

8. Land Use. Most land surrounding the Pantex Plant is dryland or irrigated farmland on broad flat plains interspersed with grassland pastures and water ponds (playas) in natural drainage areas. The average size farm is 513 hectares (1280 acres) or 2 square mi (Smith 1981). These large tracts of land are intersected only by US Highway 60, a railroad, a few gravel roads, and an occasional farmstead or rural home site. Rural housing development is greater several miles south and southwest of the Pantex Plant boundaries toward Amarillo and the airport.

Major developments in the immediate vicinity of the Pantex Plant are the Texas Tech Agricultural Research Station, the Iowa Beef Packing Plant, and the industrial park adjoining Amarillo International Airport. These facilities are located about 8, 10, and 12 km (5, 6, and 7.5 mi), respectively, southwest of the main operational area at the Pantex Plant.

No negative land uses are projected with any of the construction options. Replacement of the plant would encroach on additional tracts of cropland and grassland within the present site boundaries. However, demolition and removal of present facilities may result in restoration of some land to agricultural uses.

III. IOWA ARMY AMMUNITION PLANT

A. General Description of the Area

The IAAP is located near Burlington, Iowa, on the banks of the Mississippi River in southeastern Iowa. Burlington is located about 150 mi southeast of Des Moines, Iowa, and approximately 75 mi downriver from Davenport, Iowa. Four counties in Iowa represent the geographic boundaries of the Southeast Iowa trade area. They are Des Moines, Henry, Lee, and Louisa Counties.

The IAAP is located along the southern boundary of Des Moines County immediately adjacent to the municipal boundaries of West Burlington, Iowa. The installation covers over 19 300 acres of land with an average elevation just over 600 feet above sea level. The terrain ranges from flat, high-quality agriculture ground (about 60% of the area) to hilly, rough pastureland, traversed by three small creeks (USDOD 1979).

Before acquisition of the plant site by the Federal government, the land was occupied by many farms, seven cemeteries, and two old one-room schoolhouses. Some of the farm homes were moved to the present administrative area of the Plant to provide housing. One schoolhouse and two of the original seven cemeteries remain.

The Southeast Iowa trade area supports an intensive agribusiness economy, yet agriculture employs only a small fraction of the labor force. In Des Moines County, for example, agriculture employs 6% of the labor force. Manufacturing employs about 32%, and the rest of the labor force is employed in nonmanufacturing industries and services (Appendix C, Item 2).

The assessment methodology described for the Pantex Plant operation was followed for the Southeast Iowa trade area.

B. Current Population and Employment

The 1980 US census count for the four Iowa counties in the Southeast Iowa trade area totaled 120 254. Burlington and West Burlington, adjacent to the east boundary of the Plant site, had a combined population of nearly 33 000 in 1980. Fort Madison (9 mi southeast) and New London (8 mi northwest of the plant) reported approximately 13 500 and 3400, respectively.

Since 1970, the population of the four counties has grown only 1.2% and only 4.6% since 1950. The increase in population since 1950 compares with the state growth of 11.2% and the national growth of 50.3% in the same period (Appendix C, Item 2). Relatively few young people enter the labor force of the area. At IAAP the mean age of the work force was estimated at 50 years. The relatively older work force emerged as a result of a long history of reductions in the IAAP work force level and seniority rights granted the older workers with many years of service at the Plant. For example, over 20 300 security badge numbers have been issued since Plant operation began in 1941. Of that number, at least 136 workers in the present work force (13%) hold badges numbered in the first 1000 ever issued.

In 1981 Mason and Hanger--Silas Mason Company, Inc., employed an average of 1031 workers at IAAP (Appendix C, Item 1). IAAP, located in Des Moines County, is the second largest employer in the Burlington area, and among the five largest employers within reasonable commuting distance of the plant (SIRPC 1978). The jobs at IAAP represent 1.6% of the workers employed in the Southeast Iowa trade areas and 2.0% of the resident labor force.* Approximately 20% of the workers at IAAP are female. Many women are employed on the manufacturing lines in both production and quality assurance activities.**

*Larry Holtkamp, Iowa Job Service, telephone interview, December 1981.

**R. L. Holmberg and G. H. Mathes, personal interview, July 8, 1981.

Over 86% (877) of the IAAP employees live in the Southeast Iowa trade area and nearly 10% reside across the Mississippi River in Illinois. The balance of the workers commute from as far away as northern Missouri (Appendix C, Item 2). The employees living in the Southeast Iowa trade area (as defined in this study) are distributed as follows: Des Moines County, 582; Henry County (to the west), 140; Lee County (Fort Madison area), 131; and Louisa County (to the north), 24 (Appendix C, Item 1).

An available labor supply is not expected to be a problem in the Southeast Iowa trade area. Labor force data provided for Region XVI (four counties) reported a 1980 unemployment rate of 5.8% compared to 7.1% nationally (IJS 1981C). The proximity of the IAAP area to large population centers is expected to insure a large pool of construction workers and skilled craftsmen if needed (Appendix C, Item 2).

C. Potential Change in Population and Employment

The assumptions noted in the assessment at the Pantex Plant described in Section I and Appendix A are used here. Two construction alternatives are considered for the IAAP. The first is partial relocation of only a portion of the Pantex Plant operation. The second involves total replacement of the Pantex Plant operations with a new manufacturing facility in Iowa. The second alternative is expected to require a somewhat larger work force than that noted in the analysis of Pantex Plant Option 3 because more construction projects are involved (Schnurr 1982B). Table III presents a summary of potential changes in population and employment.

TABLE III

IAAP CONSTRUCTION OPTIONS
POTENTIAL CHANGES IN POPULATION AND EMPLOYMENT

<u>Option</u>	<u>Basic Jobs</u>	<u>Nonbasic Jobs</u>	<u>Hypothetical Population Change (Construction)</u>	<u>Permanent New Operating Jobs</u>
<u>Option 1</u>				
Partial relocation	100	68	0	1000
<u>Option 2</u>				
All-new plant	1800	1224	5808*	2600

*Appendix A, Item 13C.

1. Option 1--Partial Relocation. The time frame for completion of this project is 1985. The study examines 2- and 3-year construction periods and the operational phase. At most, the construction phase would employ only about 100 basic workers and 68 nonbasic workers during the peak construction period. Population changes, if any, would be insignificant. The work force computations are documented in Appendix A, Item 11.

For Option 1 the most significant change in employment and population would occur when the facility becomes operational. Partial relocation of the Pantex Plant operation to IAAP would add approximately 1000 new permanent jobs. The increase about doubles the present work force at IAAP. However, the large labor supply currently available within commuting distance of the IAAP would virtually eliminate the need for an in-migration of workers in either the construction or operational phase of this option. Support documentation regarding the availability of the labor supply are set forth in Appendix C, Item 2.

2. Option 2--All-New Plant. The proposed construction time for building an all-new plant is the same as the Pantex Plant Option 3. For establishing a worse case scenario, the analysis considered 5- and 8-year construction periods. Thus, a range of possible impacts can be considered.

The total basic construction employment in the peak period would range from about 1526 in the 8-year scenario to 1800 in the 5-year scenario. In December 1981, the Iowa Department of Job Service indicated that as many as 4500 workers could be supplied, with little or no in-migration (Appendix C, Item 2). Therefore, the projected need of 2112 construction workers (or even 2600 operational workers upon completion) would not be a problem.

As with the Pantex Plant alternative, the study examined the implications of a hypothetical in-migration of 1500 basic construction workers plus induced employment in the service sector. As set forth in Appendix A, Item 13, the demographic assumptions would add a total of 5808 new residents within commuting distance of the construction site. The growth represents a 4.8% increase over the 1980 population for the Southeast Iowa trade area.

Two methods of analysis are used to evaluate the potential for unmanageable impacts in the Southeast Iowa trade area. The first method examines the effects on Des Moines County if the construction work force was distributed in settlement patterns similar to the present IAAP work force. The second method simply considers how many workers could Des Moines County assimilate without exceeding one-time growth greater than 10% (Appendix A, Item 3).

Under the first method Des Moines County would share 56% of the peak construction work force ($2112 \times 56\% = 1183$ workers) and a proportionate share of the new population (3252), which represents 7% growth in a one-time event. Following the method further, Burlington and West Burlington reported 71% of the

1980 Des Moines County population and could, therefore, expect 840 of the new workers with the balance (343) to locate in small communities and rural areas of Des Moines County. Complicating matters is the consistent evidence in many studies (Rapp 1980) that single workers tend to reside near their place of employment. Therefore, nearly all 525 single construction workers (basic) and a large share of the single (nonbasic) workers are expected to locate in Des Moines County. Married workers tend to seek available housing for families and consider the quality of schools and basic services.

Because of available housing and good school facilities in Burlington and West Burlington, this study projected the effects of 500 married workers and their families settling in the two cities. If the distribution methodology were rigidly followed in view of the preference of single workers, 500 families may be more than should be expected. However, 500 families involve some 1845 members including 350 school age children. If all the single workers also settled in the two cities, the total growth is less than 8% of the 1980 population.

Using the second method of analysis, even if 75% of the basic and nonbasic workers and their families (about 550 single and 1030 married) would settle in Des Moines County at one time, the temporary growth would be less than 10% of the county population (about 4350 in-migrant vs. 1980 and 1981 population of 46 300). It should be noted that 75% of the total new work force represents nearly three times the number of IAAP workers who presently reside in Des Moines County. In either analysis the remaining counties in the Southeast Iowa trade area would experience less than 5% growth (Appendix A, Item 3).

D. Current Economic Conditions

For this study the effective buying income and retail sales information considers only the four Iowa counties in the Southeast Iowa trade area. The reader is reminded of the discussion in Section I regarding the determination of the actual boundaries for the Southeast Iowa trade area, as approximately 10% of the IAAP employees reside in Illinois. As previously explained, the study chose to consider that only 90% of the current IAAP payroll contributes to the retail sales in the Southeast Iowa trade area. [It is highly probable that a much larger share of the IAAP payroll is actually spent in the trade area because (1) most of the out-of-state workers commute through Burlington or Fort Madison on a daily basis, (2) Iowa levies a much lower sales tax than does Illinois, (3) Burlington or Fort Madison very likely offers the largest and closest shopping center for most commuters residing in nearby Illinois.]

The 1980-81 payroll at IAAP was \$20.218 million. Nonbasic employment added an estimated \$18 million (\$17.994) for a total of \$38.212 million of which \$34.390 million (90%) remained in the trade area. Mason and Hanger estimates it purchases about \$1 million per year in local supplies and services. The local school districts receive an estimated \$38 000 per year in Federal impact funds

for children of IAAP employees. Thus, the total estimated contribution to the economy of the Southeast Iowa trade area exceeded \$35 million per year and resulted in \$18.4 million or about 3% of the 1981 retail sales (Appendix A, Item 12, and Appendix C, Item 1).

E. Projected Economic Change

Completion of Option 1 would generate approximately 1000 new permanent jobs and about an equal number of nonbasic jobs in the Southeast Iowa trade area. Option 2 would generate about 2600 new permanent basic jobs and an equal number of nonbasic jobs. Therefore, the long range economic benefit to the area far outweighs the temporary growth during construction.

The same data source, Sales and Marketing Management, used for the analysis at the Pantex Plant was used in Iowa. Thus, it is possible to compare economic benefits between locations and to provide a measure of the expected benefits that may be projected for the several construction options considered at either place. Table IV presents a summary of projected economic changes.

1. Option 1--Partial Relocation. This construction option would generate peak year payrolls of \$4.39 million in the 2-year scenario and \$3.736 million in the 3-year scenario. Under either scenario retail sales in the Southeast Iowa trade area would increase about 0.3%. The methodology and computations used to derive the economic benefits under each option are detailed in Appendix A, Item 11. However, as previously noted, the permanent jobs created by this option are about equal to the present employment level at IAAP. New permanent jobs would add an estimated \$33.358 million per year to the present IAAP-related payroll (Appendix A, Item 15D).

2. Option 2--All-New Plant. The combined payroll for basic and nonbasic workers in the 5-year construction scenario would total \$79.033 million annually

TABLE IV
POTENTIAL ECONOMIC CHANGES FOR THE IAAP CONSTRUCTION OPTIONS

<u>Option</u>	<u>Basic Jobs</u>	<u>Induced Jobs</u>	<u>Total Peak Year Payroll in Dollars (millions)</u>	<u>Per Cent Increase in Retail Sales</u>	<u>Permanent New Jobs</u>	<u>Permanent New Payroll in Dollars (millions)</u>	<u>Per Cent Increase in Retail Sales</u>
<u>Option 1</u> Partial relocation	100	68	4.39	0.3	1000	37.063	2.8
<u>Option 2</u> All-new plant	1800	1224	67.01 - 79.033	5.1 - 6.0	2600	96.364	7.6

during the peak year construction period. The 8-year scenario would peak at \$67.007 million per year. These scenarios imply increases of 6.0 to 5.1%, respectively, over the level of the 1981 retail sales.

The permanent work force could generate about \$96.4 million in new payroll (1981 dollars) if salaries are comparable to those paid to Plant workers and nonbasic workers in the community in the past year (Appendix A, Item 15). In addition, some increases in purchases of materials and services are expected when the plant becomes operational. (The Pantex Plant operation estimated such purchases to total \$3.5 million in 1980.) Therefore, the permanent operation at IAAP could represent a 7.6% increase in retail sales over the 1981 level reported for the Southeast Iowa trade area.

F. Community Resources

The analysis of community impacts examines only the worst case scenario associated with construction of an all-new plant (Option 2).

1. Housing. Even in the event of one-time growth approaching 10% in the worst case scenario, Burlington and West Burlington are not expected to experience more than temporary housing shortages. Housing needs could be supplied largely by existing surplus housing and mobile home sites in the two cities and surrounding Des Moines County.* Many single workers may rent rooms at several hotels in Burlington. (Some hotels stand vacant at this time, but according to Mayor Uffelman, they could be reopened quickly.) In addition, there are many large homes in the older residential areas of the city that might provide rooms (Appendix C, Item 3).

Growth in the other three counties of the southeast Iowa trade area is expected to be less than 5%. Housing in the smaller cities in these counties is considered adequate. Although few new homes are available, many older homes in these small towns have been upgraded by younger families willing to commute longer distances to places of employment. Moreover, most of these smaller cities have mobile home space available in the fringe areas.*

2. Utilities. Natural gas is supplied to the Southeast Iowa trade area by the Michigan-Wisconsin Pipeline Company and the Iowa Southern Utility Company. IAAP is supplied by an interruptible service contract; however, 1000 Btu natural gas is available in industrial quantities on a firm demand basis. The IAAP is currently converting a standby electric generation facility from fuel oil to coal, which may, in time, become the principal power source at IAAP. Presently, electric power is supplied by the Union Electric Power Company headquartered in St. Louis, Missouri, which reported the Plant was assured ample electrical power through two supply lines: one through Missouri and the other

*Roy F. Uffelman, Mayor of Burlington, telephone interview, September 10, 1981.

through Illinois.* In addition, Union Electric interconnects with the Iowa Southern Utility Company, the Central Iowa Power Supply power pool, and the Mid-America Interpool Network (MAIN). The Plant obtains water from the City of Burlington with a contract for 3.6 million gallons/day.

3. Education. Iowa's educational system is among the best in the nation. The state ranks first in literacy and second in the number of students who finish high school. At the elementary and secondary school levels, the five largest cities in the four counties average one teacher for every 15.7 students. Burlington presently has surplus school buildings, which are now leased to other users (Appendix C, Item 4).

The University of Iowa at Iowa City is within 80 highway miles of Burlington. Iowa Wesleyan College at Mount Pleasant in Henry County is a private, coeducational, four-year liberal arts college. Southeastern Community College has a main campus at Burlington with a second campus at Keokuk in Lee County.

At present, the number of IAAP workers with school age children is quite small because many of the Plant work force are older workers. In the past year, the IAAP contractor received only 56 requests for verification of employment from four school districts for the purpose of applying for Federal impact funds.

Option 2 will present few problems because surplus capacity in existing school buildings will permit timely renovation as needed. During peak construction an estimated 350 additional school age children could attend Burlington schools. This represents about an 4.6% increase over 1981 enrollment counts (7621) in Burlington and West Burlington public and private schools. If the balance of the work force is distributed in somewhat the same manner, another 611 students would be expected to be distributed throughout schools within commuting distance of the Plant. For further examination of the methodology used, see Appendix A, Items 1-14, and Appendix C, Item 4.

4. Health Services. During the past two decades, Iowa has experienced the national trend of medical providers moving from rural communities to group practices in larger trade centers. Similarly, physicians who provide specialty care practice where there is access to larger hospital facilities. The ratio of doctors to population ranges from a low of one doctor/625 at Burlington to about one doctor/2200 across the four-county health service area (Appendix C, Item 4).

The rural area is served by a Regional Health Systems Agency designed to provide rural clinics, hospital centers in the major communities, and highly specialized care at the University of Iowa Medical Center at Iowa City (SIRPC 1978).

*W. K. Smith, Executive Assistant for Regional Operations, Union Electric Company, telephone interview, June 17, 1982.

The health services in the Southeast Iowa trade area are considered quite adequate for all projected growth scenarios, including the significant increases in permanent employment opportunities associated with the operation of a new plant.

5. Public Safety. The City of Burlington employs 36 sworn officers and is supported by 13 sworn reserve officers. The ratio of police officers per capita is well within the Federal guidelines of 1/1000. Senior officers consider the authorized strength adequate for their needs. Similar findings were reported by the Des Moines County Sheriff's Office. The Burlington Fire Department employs 50 firefighters and officers for a ratio of about 1/600 population (Appendix C, Item 3).

To maintain the present ratio of sworn police officers to residents during the peak construction period, Burlington may need to add about six more officers. A similar number of firefighters would also be required.

6. Transportation. The transportation facilities serving the Burlington area are excellent. Rail freight service at Burlington is provided on the Burlington-Northern lines. Rail passenger service is provided by Amtrak. Fort Madison is served by the Burlington-Northern and Atchison, Topeka, and Santa Fe Railroads. Ozark Airlines serves the region at Burlington, and charter services are also available from the several smaller airports in the area. Burlington Airport is equipped with 10-in. concrete runways, 6700 ft long and 150 ft wide. The largest aircraft using the facility are small-sized commercial jets (for example, DC-9s). Trucking service is provided by 31 common carriers and passenger bus service by Continental Trailways. Two US highways cross the area north-south and a third crosses east-west. Water transportation is available on the Mississippi River about 10.5 months of the year (SIRPC 1978).

The potential for several thousand additional workers in the Burlington area may create temporary traffic problems near the Plant site during shift changes. Carpooling and busing could minimize the problem.*

7. Quality of Life--Cultural Resources. The Burlington Chamber of Commerce reported an unusually large number of cultural activities for a city of Burlington's size: the Southeastern Iowa Symphony, a Chamber music group, the Bel Canto Chorale, theater at Southeastern Iowa Community College, libraries, closed-circuit television, the Des Moines County Historical Museum, Snake Alley, Burlington Players Workshop, annual arts and crafts show, Steamboat Days, Midwest Old Settlers Days, County fairs, rodeos, indoor and outdoor sports areas, water sports, and scenic parks. Projected growth from the proposed action is not expected to negatively impact the cultural resources of the area.

*Roy F. Uffelman, Mayor of Burlington, telephone interview, September 10, 1981.

8. Land Use. Land use at the IAAP site involves several thousand acres in buildings, roads, open spaces, and storage areas. The cropland presently under lease at IAAP totals about 7000 acres and the pastureland totals about 2000 acres. Both land uses are scattered throughout many locations on the Plant site and are overseen by professional management (USDOD 1979).

Beyond the IAAP boundaries the terrain is dominated by the escarpment above the Mississippi River bottomlands. The upperland is generally flat to moderately rolling plains with pastures on the poorer, steeper slopes, and timber regions in the rougher areas along the waterways. The Skunk River Valley provides the irregular shape to the southern boundary of the IAAP site.

The area surrounding the IAAP is composed of about 61% cropland, 11% pastureland, and 15% woodland. The remainder is urbanized, interspersed with open space, State and Federal lands, waterways, or other nonagricultural uses. The heavy rainfall in the area permits intensive farming practices on units that average about 200 acres in size. As a result, it is not uncommon to observe three or more residences on a square mile of highly productive land. Construction of a new nuclear weapon operations facility would change land uses within the boundaries of the IAAP from agriculture and woodlands to industrial uses but would produce little impact on land uses in surrounding areas.

Several villages border the IAAP site on the south, west, and north sides. The population centers around IAAP are summarized in Table V.

IV. HANFORD SITE

A. General Description of the Area

The Hanford Site occupies about 360 100 acres of semiarid rangeland in parts of Benton and Franklin Counties in southeastern Washington, just northwest

TABLE V

COMMUNITIES SURROUNDING THE IOWA ARMY AMMUNITION PLANT

<u>City</u>	<u>Population</u>	<u>Direction</u>	<u>Distance (miles)</u>
Augusta	100	S	0
Burlington	29 529	E	0
Danville	995	NW	1.5
Denmark	200	SW	2.3
Fort Madison	13 520	S	9.2
Middletown	487	N	0
New London	2 046	NW	7.7
West Burlington	3 373	E	0

of where the Yakima and Snake Rivers join the Columbia River. The two counties comprise the Benton-Franklin trade area as well as the Richland-Kennewick-Pasco SMSA. The sparsely populated land surrounding the Hanford Site was first settled by homesteaders late in the 19th century. Farming has been generally restricted to areas along the rivers where irrigation waters can be developed. Much of the open space surrounding the Site is occupied by large ranches.

Since 1943, the population of the trade area (SMSA) has grown dramatically in the cities of Richland and Kennewick in Benton County and Pasco in Franklin County. The three cities are referred to in this study as the Tri-Cities. Although much of the original rapid growth was attributed to government work on the Hanford Site, a more diversified economy and service community has developed with private sector development of research facilities, fuel processing, waste management, and especially nuclear generation facilities (USDOE 1980A and USDOE 1980B).

B. Current Population and Employment

The 1980 US census population for the SMSA (by definition all of Benton and Franklin Counties) reported 149 000 residents. The total represents nearly a 55% increase over the combined 1970 census figure or about five times the national growth rate in the same period. Benton County, with the rapidly growing cities of Richland and Kennewick, experienced a growth rate of 78% in the past decade, whereas Franklin County, with the city of Pasco, grew 43%. Within the municipal boundaries of the Tri-Cities, the census reported a combined population of nearly 88 000 in 1980 (WJS 1981A).

As of January 1981, the Hanford Site and related DOE operations in Franklin and Benton Counties employed approximately 12 000 workers. However, also on the Hanford Site were approximately 11 500* workers employed by the Washington Public Power Supply System (WPPSS) for construction of three nuclear power generation plants. (Late in 1981, much of the construction activity by WPPSS was canceled, although work has continued on one generation unit.) Recent WPPSS work force information projects 1984 work force levels at 25% of the peak employment in January 1981, then declining to permanent operating levels of just over 700 employees by 1986 (Appendix D, Item 1).

Within commuting distance of the Tri-Cities are other construction activities, particularly the Priest Rapids and Wanapum Dam projects where over 1100 construction workers will be employed (Appendix D, Item 1).

The resident labor force for the trade area (SMSA) was reported at 82 340 in 1981 with total unemployment at 7320 (8.9%) (Appendix D, Item 1). In view

*Subsequently reported as 10 456 (Appendix D, Item 1). This information became known after preparation of the draft EIS and will be corrected in the final document.

of the many construction workers moving in and out of the area during different phases of construction on nuclear electric generation plants and nearby dams, there appears to be no shortage of workers. For the state as a whole, construction employment has declined since 1979. Therefore, a large work force appears to be available (Appendix D, Item 1). (For further information, see USDOE 1980A, USDOE 1980B, WPPSS 1979, WPPSS 1980, and TCCC 1981B.)

C. Potential Changes in Population and Employment

Only one construction option (an all-new plant) is projected for the Hanford Site. Table VI provides a summary of the economic changes detailed more fully in Appendix A, Items 11 and 15.

Option 1--All-New Plant. The proposal to construct a new weapons plant on the Hanford Site is similar to the Pantex Plant Option 3 and IAAP Option 2 (Schnurr 1982B). The principal statistical difference is the adjustment in hourly wages as noted in Assumption 2 of Appendix A. Manpower requirements and nonbasic employment computations are the same as used for IAAP. Thus, the basic employment would peak at 1800 workers and 1224 nonbasic workers in the 5-year scenario. The 8-year scenario would employ about 1526 basic workers and 1038 nonbasic workers during peak employment periods. The entire work force requirements could be supplied by available labor and local sources as noted in communications and data supplied by the Washington State Employment Security Department (Appendix A, Item 11, and Appendix D, Item 1).

As with the other potential sites, the study considers the implication of an in-migration of 1500 construction workers and 612 nonbasic workers. The addition of 5808 new residents represents a 3.9% increase in population for the trade area. The hypothetical scenario is not expected to ever develop because of the large labor supply available in the SMSA (WJS 1980 and WJS 1981B).

Upon completion of an all-new plant, the permanent operating work force would provide 2600 basic jobs and approximately 2600 nonbasic jobs (Appendix A,

TABLE VI
POTENTIAL ECONOMIC CHANGES FOR THE HANFORD CONSTRUCTION OPTIONS

Option	Basic Jobs	Induced Jobs	Total Peak Year Payroll in Dollars (millions)	Per Cent Increase in Retail Sales	Permanent New Jobs	Permanent New Payroll in Dollars (millions)	Per Cent Increase in Retail Sales
<u>Option 1</u> Plant replacement	1800	1224	70.39 - 83.03	4.3	2600	113.969	6

Item 15C). Because of the continuous construction and industrial activity in the area, no problems are anticipated in securing a permanent work force.*

D. Current Economic Conditions

Payroll directly attributed to Hanford operations could not be fixed because of various contractor work force fluctuations. However, a conservative estimate of basic payrolls totals \$545 million in 1981. The nonbasic employment is estimated to add nearly 20 000 jobs generating an additional \$485 million. (See Appendix A, Item 14.)

Combined retail sales for the trade area in 1981 were \$923.828 million (Appendix A, Item 17). The combined payrolls for basic and nonbasic employment at the Hanford Site generated about \$1030 million. Therefore, retail sales would increase \$612.85 million or about 66% of the 1981 retail sales (Appendix A, Item 14).**

In 1981, the three independent school districts in the Tri-Cities area will receive an estimated \$782 000 in Federal impact funds for children of Federal workers employed at the Hanford Site. This total represents approximately 97% of all funds paid to area school districts (WPPSS 1979).***

E. Projected Economic Change

The basic and nonbasic employment payroll during peak year construction would range from \$70.394 million in the 8-year scenario to \$83.027 million in the 5-year scenario. Accordingly, retail sales in the trade area would increase 3.6 to 4.3% above the total 1981 retail sales.

The permanent operating payrolls computed at prevailing wage rates noted in Appendix A, Item 2, would add over \$117 million per year (in 1981 dollars) to the area's economy. The permanent payrolls would result in about a 6% increase over 1981 retail sales in the area (Appendix A, Item 15C).

F. Community Resources

1. Housing. The Tri-Cities Real Estate Research Report, published in the spring of 1981, indicates 85 units for sale (less than one-half the number

*Dean Schau, Labor Management Economics, State of Washington Employment Security Department, telephone interview, April 7, 1982.

**Calculations based on early information showed these values to be about \$490 million or 53%; these early calculations were used in the draft EIS. The more recent data, as shown in this report, will be used in the final EIS.

***Dr. Robert Iller, Superintendent, Richland Public Schools; Dr. Don Anderson, Superintendent, Kennewick Public Schools; and Ms. Laurel Hammond, Business Manager, Pasco Public Schools; telephone interviews; October 1981.

available 6 months earlier). However, the majority of new homes available were relatively higher priced homes (\$70 000+). The study also noted a 16.7% vacancy rate among some 6000 apartment units in the Tri-Cities area. The availability of housing is attributed to the shifts in construction activities in the area. In many cases construction workers provide their own mobile housing, as evidenced by numerous mobile home parks in the area (TCRERC 1981).

2. Utilities. Natural gas is supplied to the Tri-Cities area by Cascade Natural Gas Company headquartered in Seattle, Washington. Cascade is a distributor for the Northwest Pipeline Corporation of Salt Lake City. The new high-pressure distribution system was installed in 1956. The reserve life index of 21.3 years is reported to be the highest of any major company.*

The Tri-Cities area provides municipally owned water and sewer services. Electric power is supplied in the area by the Franklin County and Benton County Public Utility Districts and by Richland Energy Services. Telephone service is provided by General Telephone Company of the Northwest, Inc., in Kennewick and Richland and also by the Pacific Northwest Bell Telephone Company in Pasco (TCCC 1981B). No shortages in utility services are expected.

3. Education. The 3 public school districts operate a total of 26 elementary schools, 7 middle or junior high schools, 5 high schools, and 1 alternative high school. In addition, the area supports 8 parochial schools with an enrollment of over 1400 students. The Columbia Basin College in Pasco is a 2-year accredited college. The Joint Center for Graduate Study in Richland, administered jointly by the University of Washington, Washington State University, and Oregon State University, offers academic programs leading to advanced degrees. Both Whitman College and Walla Walla College, located within 50 mi of the Tri-Cities, offer 4-year programs.

At the beginning of the 1981-1982 school year, area schools had an enrollment of 35 300 students.** The ratio of teachers to students was less than 1:25 in all school systems except in elementary schools in Pasco that averaged 1:29. The addition of 961 students under the hypothetical scenario would add about 2.7% more students. The schools in the Tri-Cities should be able to accommodate the small growth without any difficulty (USD OE 1980B).

*John Crogran, Public Information Officer, Cascade Natural Gas Company, and Owen Zuro, Public Information Officer, Northwest Pipeline Corporation, telephone interviews, June 15 and 16, 1982.

**Dr. Robert Iller, Superintendent, Richland Public Schools; Dr. Don Anderson, Superintendent, Kennewick Public Schools; and Ms. Laurel Hammond, Business Manager, Pasco Public Schools; telephone interviews; October 1981.

4. Health Services. The Tri-Cities are served by 3 hospitals with a total of 276 beds or about 1.9 beds/1000 population. The ratio compares to Federal guidelines that recommend 4 beds/1000 residents. The hospitals reported an occupancy rate that varied from 63, 69, and 80% in the past year. The Kadlec Hospital in Richland is currently seeking certification of need for 64 additional beds in 1982.*

The Benton-Franklin Medical Society listed a total of 162 medical doctors in the Tri-Cities area for a ratio of approximately one doctor/920 population (BFCMS). This ratio is well within the recommendations set forth in Federal guidelines.

5. Public Safety. The Pasco Police Department has 28 sworn officers, providing a ratio of 1.5 officers/1000 population. Kennewick reported 47 sworn officers providing a ratio of 1.3 officers/1000 population. In addition, the Department has a 30-officer reserve force. Richland has 43 sworn officers, providing a ratio of 1.4 officers/1000 population. Senior officers in all three departments considered their authorized strength as adequate to excellent.

The Benton County Sheriff's Office reported 30 road deputies, providing a ratio of 0.9 deputies/1000 population, which was believed to be adequate. The Franklin County Sheriff's Office reported 17 sworn officers with a ratio of 0.8 officers/1000 population. The Undersheriff advised that a need for an additional seven deputies was recently announced by the Sheriff.**

Fire departments in the 3 cities reported personnel strength: Richland, 40; Kennewick, 33 plus 15 volunteers; and Pasco, 27. The three departments have entered into a mutual-aid agreement that triples the fire protection offered area residents (TCCC 1981B). The modest growth associated with the proposed Pantex Plant replacement will not significantly alter the present level of public safety protection.

6. Transportation. The Tri-Cities are interconnected by US Highway 12. Other major roads serving the region are US 395 and State Highways 14, 24, and 240. Interstate Highways I-82 and I-182 are still in the planning stages. In September 1981 Amtrak service was restored to the area. Rail service includes the Burlington Northern and the Union Pacific Railroad Companies. Air service is provided at the Tri-Cities Airport at Pasco by Republic Airlines and a commuter airline, Cascade Airways. The commuter airline also serves the Richland Airport. The Kennewick Airport only serves general aviation traffic.

*Connie Thornburg and Peggy Monter, Kadlec Hospital Planning Staff, Richland, Washington, telephone interview, October 23, 1981.

**Capt. Casparek, Pasco Police Department; Capt. Waldner, Kennewick Police Department; Undersheriff Bow, Benton County; and Undersheriff Courson, Franklin County; telephone interviews; June 15, 1982.

Motor freight service is provided by over 20 interstate and intrastate truck-lines. Passenger service is provided by the Greyhound Bus Lines. Barge service on the Columbia and Snake Rivers is provided by three companies. The Tri-Cities area supports three operating river port facilities (TCCC 1981B).*

7. Quality of Life. The Tri-Cities offer an extensive range of cultural activities and recreational facilities. These include the mid-Columbia Symphony, Richland Light Opera Company, Richland Players, Community Concert Series, water follies, hydroplane races, rodeo, horse racing, college theater, and art galleries. Outdoor sports are available both winter and summer (TCCC 1981B).

8. Land Use. Land use within 5 mi of the proposed plant lies entirely within the boundaries of the Hanford Site. The Columbia River traverses the Hanford Site in a circular route, and thus, about 7 mi of its length lies within 5 mi of the proposed construction site. Across the river to the northwest but within 5 mi of the proposed plant is Hanford Site land managed by the US Fish and Wildlife Service. No operating facilities are north of the river. However, south of the river, land use within 5 mi of the proposed construction site includes the Hanford Generating Project, the Near-Surface Test Facility, and a fire station. Also included are associated roadways, railroads, and transmission corridors. Much of the land between facilities is covered with native grasses.

The nearest Hanford Site boundary to the proposed plant lies across the river about 8 mi northwest beyond State Highway 14. State Highway 240 crosses the southwest corner of the Hanford Site, but the highway is not any closer than 8 or 9 mi at its nearest point to the proposed plant.

Beyond the Hanford Site boundaries are farms and large tracts of grazing land. The nearest population center is Richland, approximately 20 mi southeast of the proposed construction site (USDQE 1980A).

ACKNOWLEDGMENTS

The author wishes to thank Dave Abbey of the Economics Group (S-2), Los Alamos National Laboratory, for his assistance in reviewing this manuscript.

*Clark Stolle, Benton Franklin Government Conference, personal interview, August 27, 1981.

APPENDIX A

METHODOLOGY

SOCIOECONOMIC ASSESSMENT

The socioeconomic assessment of current conditions in the three locations under study is based on numerous data sources and conversations with officials in government and with persons in private organizations. Where practical, the information was incorporated into the text. However, conclusions were also drawn from observations and/or assumptions made by the author based on interpretation of raw data. The following is an explanation of the major assumptions used in this socioeconomic analysis.

1. Project costs and timetables for construction provided the basis for each scenario and for the alternatives examined. With each alternative, except Pantex Plant Option 1, two timetables for the construction activity were assumed even when not specifically set forth in the description of the alternative action (Schnurr 1982B). The conclusions set forth in Chapter 4 of the EIS are based on a range of possible socioeconomic effects that may be expected from any alternative action. The proposed total construction costs associated with the first three alternative actions at the Pantex Plant were taken from Schnurr (1982B).

In addition, several ongoing construction activities at the Pantex Plant totaling \$53 million will continue under the no-action option or with partial relocation of nuclear weapons operations to the IAAP.

Construction costs at the IAAP were \$163 million and \$1488 million. At the Hanford Site only one alternative was considered at a cost of \$1552 million. The differences in construction costs are explained in Item 2.

The basic work force requirement for each construction project if completed in 5 years would range from a peak of 459 jobs/year for Option 1, 1000 jobs/year for Option 2, and 1600 jobs/year for Option 3 at the Pantex Plant and 1800 jobs/year for Option 2 at IAAP and Hanford Site. A peak construction work force level was computed at 150% of the average work force levels in the 5-year scenario and 130% in the 8-year construction period.

2. The average prevailing wage in the Amarillo area was reported to be approximately \$17/hour for basic construction. The socioeconomic assessment assumed the prevailing hourly rate to be \$17/hour for basic workers and \$8/hour for nonbasic workers in the Amarillo trade area.

Total costs of construction at the IAAP and at the Hanford Site were adjusted by use of the 1981 Berger Building and Design Cost File. The document provided a comparative index of construction costs in a subregion with an index of 100 representing the national average. The Amarillo area was indexed at 85.4; the St. Louis area, 93.9; and Spokane, 98.6. Thus, wages assumed for the IAAP and the Hanford site were 10% and 15% greater, respectively, than the Amarillo base.

3. Negative socioeconomic impacts are expected to adversely affect the local government infrastructure when a jurisdiction experiences population growth greater than 5% per year for several years or 10% growth in any one year. Lesser impacts typically do not exceed the assimilative capacity of an existing facility or service, although small additional costs for personnel may occur. This assumption is supported by numerous studies of boomtown problems conducted by social science research organizations and individuals (Gilmore 1975).
4. Total construction employment assumed a multiplier of 1.68 times the basic employment levels (USCC 1973). A multiplier of 2.0 was used to determine total employment levels associated with the permanent operating work force following the construction phase.

It should be noted that nonbasic to basic employment multipliers continue to be grossly overstated in many EIS documents and demographic studies. This finding has been reported in numerous recent case studies in the western states where early construction work force projections used 1.2 to 2.0 and even 3.2 in one case (Rapp 1980, DRI-BBC 1982, and OWRC 1975). Case studies of actual construction activities have demonstrated that the nonbasic multiplier varies with the economic size of the region involved. The more complete existing services are in an area, the smaller the in-migration of new population needed to provide services to the temporary construction work force.

5. The ratio of single workers to married workers was assumed to be 35% single and 65% married. The justification is based on the studies cited in Item 4, and those of the Tennessee Valley Authority and the Inter-Industry Technical Assistance Team--a consortium of industries in North Dakota as reported in the uranium study (Rapp 1980).
6. Average household size was assumed to be 2.75 persons/household. This ratio was supported by the studies previously noted in Items 4 and 5 and also falls within the range of the average household size reported for Texas, Iowa, and Washington. See 1980 US Census of Population (that is, Amarillo, 2.66 persons/household; Burlington, 2.72 persons/household; and Richland-Kennewick-Pasco, 2.80 persons/household).

7. It was assumed that each married worker who moves his family to the impacted area will average 0.7 children of school age. This compares with about 0.66 school age children of Pantex Plant employees at present and is consistent with the case studies noted previously. The national trend for smaller families is even more pronounced in construction worker families, where often both the husband and wife are employed either directly or indirectly at the construction project (Rapp 1980).
8. A national journal, Sales and Marketing Management (S&MM 1982), provides the common source for all locations for the 1980 US Census of Population update, effective buying income, and retail sales of US markets. It was assumed this document provided the basis for an accurate comparison of the economic tradeoffs between all actions and alternative locations in thhs study. (See also Appendix A, Item 17.)
9. Payrolls associated with each alternative construction scenario were reduced by 20% to reflect personal taxes and related payments. The resulting figure then represents the potential buying income in a market area.
10. The ratio of retail sales to the effective buying income in a trade area can be calculated from the data reported in the Sales and Marketing Management journal for 1981. The ratio was used as a multiplier to determine the contribution of new buying income associated with each alternative action to future retail sales in the trade area. Accordingly, the ratio (multiplier) derived for the Amarillo area was 64.5% of new buying income; Burlington, 64.9%; and Richland-Kennewick-Pasco, 59.5%.

11. Site-Specific Computations*

Pantex Plant Option 1

Given:

- a) Construction time frame: 7 years
- b) New construction: \$198 million
- c) Basic employment: $\$17/h \times 8 h \times 220 d = \$29\ 920/yr$
- d) Nonbasic employment: $\$8/h \times 8 h \times 230 d = \$14\ 720/yr$
- e) Peak year construction labor force: 459
- f) Nonbasic employment: 0.68/1.0 basic job
- g) Buying income: 80% of total payroll
- h) Retail sales: 64.5% of buying income
- i) Total 1981 retail sales in area: \$1759.497 million

*See Schnurr (1982B).

Methodology

Peak year 459 basic jobs x 29 920/yr = \$13.763 million
459 x 0.68 = 312 nonbasic jobs x \$14 720/yr = 4.593 million
Combined Payroll = \$18.356 million
\$18 356 million x 80% x 64.5% = \$9.472 million in new retail sales ÷
\$1759.497 million = 0.54% increase over total 1981 retail sales
in area.

Pantex Plant Option 2

Given:

- a) Construction time: 5 years
- b) Alternative time: 8 years
- c) Total construction cost: \$664 million
- d) Peak labor force = 1000 jobs in 5-yr scenario
- e) Peak labor force = 858 jobs in 8-yr scenario
- f) Basic worker paid \$29 920/yr
- g) Nonbasic worker paid \$14 720/yr
- h) Nonbasic employment 0.68/1.0 basic job
- i) Buying income 80% of total payroll
- j) Retail sales 64.5% of buying income
- k) Total 1981 retail sales in area \$1759.497 million

Methodology

5-yr scenario

1000 basic x \$29 920/man/yr = \$29.920 million
1000 basic x 0.68 = 680 nonbasic jobs x \$14 720 = 10.010 million
Combined Payroll = \$39.930 million
\$39.930 million x 80% x 64.5% = \$20.604 million in new retail sales ÷
\$1759.497 million = 1.2% increase over 1981 retail sales in the area.

8-yr scenario

858 basic x \$29 920/man/yr = \$25.671 million
858 basic x 0.68 = 583 nonbasic jobs x \$14 720 = 8.582 million
Combined Payroll = \$34.253 million
\$34.253 million x 80% x 64.5% = \$17.675 million in new retail sales ÷
\$1759.497 million = 1.0% increase over 1981 retail sales in the area.

Pantex Plant Option 3

Given:

- a) Construction time: 5 years
- b) Alternate time: 8 years
- c) Total construction cost: \$1239 million
- d) Peak labor force = 1600 basic jobs in 5-yr scenario
- e) Peak labor force = 1224 basic jobs in 8-yr scenario

- f) Basic worker paid \$29 920/yr
- g) Nonbasic worker paid \$14 720/yr
- h) Nonbasic employment 0.68/1.0 basic job
- i) Buying income 80% of total payroll
- j) Retail sales 64.5% of buying income
- k) Total 1981 retail sales in area \$1759.497 million

Methodology

5-yr scenario

1600 basic x \$29 920 = \$47.872 million
 1600 basic x 0.68 = 1088 nonbasic jobs x \$14 720 = 16.015 million
 Combined Payroll = \$63.887 million
 \$63.887 million x 80% x 64.5% = \$32.966 million in new retail sales ÷
 \$1759.497 million = 1.9% increase over 1981 retail sales in the area.

8-yr scenario

1224 basic x \$29 920 = \$36.662 million
 1224 basic x 0.68 = 832 nonbasic jobs x \$14 720 = 12.247 million
 Combined Payroll = \$48.910 million
 \$48.910 million x 80% x 64.5% = \$25.238 million in new retail sales ÷
 \$1759.497 million = 1.4% increase over 1981 retail sales in the area.

Pantex Plant Option 4 (also Pantex Plant portion of IAAP Option 1)

Total construction cost: \$53 million

New employment will be negligible.

217 basic jobs x \$29 920/yr = \$6.493 million
 148 nonbasic x \$14 720 = \$2.179 million
 Combined Payroll = \$8.671 million

\$8.671 million x 80% x 64.5% = \$4.474 million in new retail sales ÷
 \$1759.497 million = 0.3% increase over 1981 retail sales in the area.

IAAP Option 1

Given:

- a) Construction time: 2 years
- b) Alternate construction time: 3 years
- c) Total construction cost: \$163 million
- d) Peak labor force = 100 basic jobs in 2-yr scenario
- e) Peak labor force = 85 basic jobs in 3-yr scenario
- f) Basic worker paid \$32 912/yr (110% of Pantex Plant)
- g) Nonbasic worker paid \$16 169/yr
- h) Nonbasic employment 0.68/1.0 basic job
- i) Buying income 80% of total payroll
- j) Iowa share of the total payroll is 90%.
- k) Retail sales 64.9% of buying income
- l) Total 1981 retail sales in area \$613.664 million

Methodology

2-yr scenario

100 basic x \$32 912/yr = \$ 3.291 million
100 basic x 0.68 = 68 nonbasic jobs x \$16 169/yr = 1.099 million
Combined Payroll = \$ 4.390 million

\$4.39 million x 90% = \$3.951 million.

\$3.951 million x 80% x 64.9% = \$2.051 million in new retail sales ÷
\$613.664 million = 0.3% of total 1981 retail sales in the area.

3-yr scenario

85 basic x \$32 912/yr = \$2.798 million
85 basic x 0.68 = 58 nonbasic jobs x \$16 169/yr = .938 million
Combined Payroll = \$3.736 million .

\$3.736 million x 90% = 3.362 million.

\$3.362 million x 80% x 64.9% = \$1.746 million in new sales ÷ \$613.664 million
= 0.3% of total 1981 retail sales in the area.

Pantex Plant share 217 basic jobs x 29 920/yr = \$6.493 million
148 nonbasic jobs x 14 720/yr = 2.179 million
Combined Payroll = \$8.672 million

8.672 x 80% x 64.5% = \$4.475 million in new retail sales ÷ \$1759.497 million
= 0.3% increase over 1981 retail sales in the area.

IAAP Option 2

Given:

- a) Construction time: 5 years
- b) Alternate construction time: 8 years
- c) Total cost of construction: \$1488.0 million
- d) Peak labor force = 1800 basic jobs in 5-yr scenario
- e) Peak labor force = 1526 jobs in 8-yr scenario
- f) Basic workers paid \$32 912/yr (110% of Pantex Plant)
- g) Nonbasic workers paid \$16 169/yr
- h) Nonbasic job 0.68/1.0 basic job
- i) Buying income 80% of total payroll
- j) Iowa share of the total payroll = 90%
- k) Retail sales 64.9% of buying income
- l) Total 1981 retail sales in area \$613.664 million

Methodology

5-yr scenario

1800 basic x \$32 912/yr = \$ 59.242 million
1800 basic x 0.68 = 1224 nonbasic jobs x \$16 169/yr = \$ 19.791 million
Combined Payroll = \$ 79.033 million

\$79.033 million x 90% = \$71.130 million.

\$79.033 million x 80% x 64.9% = \$36.931 million in new retail sales ÷
\$613.664 million = 6.0% increase over 1981 retail sales in the area.

8-yr scenario

1526 basic x \$32 912/yr = \$50.224 million

1526 basic x 0.68 = 1038 nonbasic jobs x \$16 169/yr = \$16.783 million

Combined Payroll = \$67.007 million

\$67.007 million x 90% = 60.306 million.

\$60.306 million x 80% x 64.9% = \$31.311 million in new retail sales ÷

\$613.664 million = 5.1% increase over 1981 retail sales in the area.

Hanford Option 1

Given:

- a) Construction time: 5 years
- b) Alternative construction time: 8 years
- c) Total cost of construction: \$1552 million
- d) Peak labor force = 1800 basic jobs in 5-yr scenario
- e) Peak labor force = 1526 basic jobs in 8-yr scenario
- f) Basic worker is paid \$34 566/yr
- g) Nonbasic worker is paid \$17 000/yr
- h) Nonbasic job 0.68/1.0 basic jobs
- i) Buying income 80% of total payroll
- j) Retail sales 59.5% of buying income
- k) Total 1981 retail sales in area \$923.828 million

Methodology

5-yr scenario

1800 basic x \$34 566/yr = \$ 62.219 million

1800 basic x 0.68 = 1224 nonbasic jobs x \$17 000/yr = \$ 20.808 million

Combined Payroll = \$ 83.027 million

\$83.027 million x 80% x 59.5% = \$39.521 million in new retail sales ÷

923.828 million = 4.3% increase over 1981 retail sales in the area.

8-yr scenario

1526 basic x \$34 566/yr = \$52.748 million

1526 basic x 0.68 = 1038 nonbasic jobs x \$17 000/yr = \$17.646 million

Combined Payroll = \$70.394 million

\$70.394 million x 80% x 59.5% = \$33.508 million in new retail sales ÷

\$923.828 million = 3.6% increase over 1981 retail sales in the area.

12. Present Estimated Contribution to an Area's Population, Tax Base, and Retail Sales from the Current Operation of Pantex Plant at Amarillo and/or IAAP at Burlington

- A. Pantex Plant basic and nonbasic employment: 2371 x 2.0 = 4742 jobs
- 4742 jobs x 2.75 persons/household = 13 040 pop.
- 13 040 ÷ 276 342 (1980 population of trade area) = 4.7% of pop.

- B. Pantex Plant basic employment payroll = \$ 54.4 million
 2371 nonbasic jobs x \$20 452/man/yr = 48.5 million (estimated)
 Pantex Plant local purchases = 3.5 million
 Total estimated local contribution = \$106.4 million
- C. Pantex Plant contribution to local taxes: \$106.4 million x 20% = 21.2million/yr
 Pantex Plant contribution to retail sales:
 \$106.4 million x 80% x 64.5% = \$54.90 million ÷ \$1759.497 million = 2.8%
- D. IAAP basic and nonbasic employment: 1031 x 90% x 2.0 = 1856 jobs
 1856 jobs x 2.75 persons/household = 5104 pop.
 5104 ÷ 120 600 (1980 population of trade area) = 4.2% of pop.
- E. IAAP basic employment payroll = \$20.218 million/yr
 IAAP nonbasic payroll = 17.994 million/yr
 IAAP combined total payroll = 38.212 million/yr
 90% of \$38.212 million retained in trade area = 34.390 million/yr
 IAAP local purchases = 1.000 million/yr
 Total estimated contribution to Southeast Iowa trade area= \$35.390 million/yr
- F. IAAP contribution to local taxes:
 20% of \$35.390 million = \$7.078 million/yr
 IAAP contribution to retail sales in Southeast Iowa trade area:
 \$35.390 million x 80% x 64.9% = \$18.374 million ÷ \$613.664 million
 = 3% of total 1981 retail sales in the Southeast Iowa trade area.

13. Demographic Assumptions for the Worst Case In-Migration Scenario

- A. Basic employment
 1500 workers:
 35% single = 525
 65% married = 975
- 1500 workers x 2.75/household = 4125 new residents
 less single workers = (525)
 married workers and families = 3600
- B. Nonbasic employment
 68% of 1500 = 1020 nonbasic jobs
 less 40% local employment = 612 in-migrant workers
 35% single (612 x 35%) = 214
 65% married = 398

612 workers x 2.75/household = 1683 new residents
 less single workers = (214)
 married workers and families = 1469

C. Combined new population
 Basic (1500) + nonbasic (612) = 2112 jobs filled by in-migrants
 single workers (basic and nonbasic) = 739
 married workers (basic and nonbasic) = 1373
 1373 married workers and families = 5069 or 3.69 persons/household*
 Total population (5069 + 739) = 5808 total new residents

D. School age children
 1373 married workers x 0.7/family = 961 children of school age
 (for example, Amarillo):
 961 children x 90% = 865 new students in AISD and 96 students
 distributed in surrounding school systems.

14. Hanford Site Payroll and Economic Computations for Current Operations

Total basic employment associated with the Hanford Site by various
 contractors was estimated at 23500 workers: (12000 DOE + 11500 WPPSS)
 Nonbasic employment = 19820 jobs: (12000 associated with DOE permanent
 employment plus 7820 associated with WPPSS construction
 (11500 x 0.68 = 7820)

The median effective buying income projected by S&MM (1981) is
 \$23 192/household.

23 500 jobs at \$23 192 = \$ 545 million
 nonbasic jobs (89% of \$545 million) = 485 million
 Total combined payroll \$1030 million

\$1030 million x 59.5% = \$612.85 million in retail sales ÷
 \$923 828 million = 66% of the 1981 retail sales in the trade area.

15. Economic Benefits from Future Operating Work Force Levels Plus Induced
 Employment

- a) Assumes local work force multiplier of 2.0
- b) Assumes net induced work force payroll per person is computed at 89% of
 direct payroll (Texas Industrial Commission) as derived by division of
 the net new (induced) economy-wide wages and salary by the net number of
 new induced jobs. (\$225 215 998 - \$54 400 000) ÷ (10 752 - 2400)
 = \$20 452 ÷ \$22 943 (current average salary) = 89%.

*Adjusted average.

A. Pantex Plant Option 1
 200 new jobs at \$22 943/man/yr = \$4.589 million/yr
 200 nonbasic jobs at \$20 452/man/yr = 4.090 million/yr
 Combined total estimated at \$8.679 million/yr

\$8.679 million x 80% x 64.5% = \$4.478 million in new retail sales ÷
 \$1759.497 million = 0.3% of total 1981 retail sales.

B. Pantex Plant Option 2
 Same as Pantex Plant Option 1

C. Pantex Plant Option 3
 Same as Pantex Plant Option 1

D. Pantex Plant Option 4
 100 new jobs at \$22 943/man/yr = \$2.294 million/yr
 100 nonbasic jobs at \$20 452/man/yr = 2.045 million/yr
 Combined total (estimated) \$4.339 million/yr

\$4.339 million x 80% x 64.5% = \$2.24 million in new retail
 sales ÷ \$1759.497 million = 0.1% of total 1981 retail sales.

E. IAAP Option 1
 1000 new permanent jobs (at present IAAP
 salary levels) = \$19.610 million/yr
 1000 nonbasic jobs (approximately 89%
 of \$19.610 million) = \$17.453 million/yr
 Combined total (estimated) \$37.063 million/yr
 Assuming 90% of new workers reside in trade area, \$37.063 million x
 90% = \$33.358 million.

\$33.358 million x 80% x 64.9% = \$17.319 million in new retail
 sales ÷ \$613.644 million = 2.8% of total 1981 retail sales in the
 trade area.

F. IAAP Option 2
 2600 new permanent jobs (at present IAAP salary
 levels) = \$50.986 million/yr
 2600 nonbasic jobs (89% of \$50.986 million) = 45.378 million/yr
 Combined total payroll = \$96.364 million/yr
 Assuming 90% of workers live in the trade area
 (\$96.364 million x 90%) = \$86.728 million/yr
 Local purchases (estimated) = 3.500 million/yr
 Grand total \$90.228 million/yr

\$90.228 million x 80% x 64.9 = \$46.846 million in new retail sales
 ÷ \$613.644 million = 7.6% increase over 1981 retail sales in the
 trade area.

G. Hanford Site, Option 1

2600 new permanent jobs (at present estimated payroll of \$23 192 man/yr)	= \$ 60.299 million/yr
2600 nonbasic jobs (80% of \$60.299 million)	= <u>53.670</u> million/yr
Combined total payroll	= \$113.969 million/yr
Local purchases (estimated)	<u>3.500</u> million/yr
Grand total	\$117.469 million/yr

\$117.469 million/yr x 80% x 59.5% = \$55.92 million in new retail sales ÷ \$923.828 million = 6% increase over 1981 retail sales in the trade area.

16. Selected Nonbasic/Basic Employment Multiplier Estimates and Estimation Technique*

<u>Study</u>	<u>Nonbasic/Basic Employment Multiplier</u>	<u>Estimation Technique</u>
Booz, Allen and Hamilton, Inc. (1974)	0.45** - 2.00***	(not reported)
Chamber of Commerce of the United States (1973)	0.68	Case study
Colony Development Operation (1974)	0.5* - 1.0	(not reported)
	1.5	
Gilmore and Duff (1975)	0.8** - 2.2***	Ratio
Hildebrand and Mace (1953)	1.25	Least squares regression
Moody and Puffer (1970)	1.14	Least squares regression
THK Associates	2.00***	(not reported)
Thompson (1959)	1.31*	Least squares regression

*Varies with economic size of region.

**Construction phase.

***Operations phase.

Source: (Rapp 1980)

17. Trade Area Economic Statistics*

	<u>1981 Estimated Population (000)</u>	<u>1981 Retail Sales (\$000)</u>	<u>Total EBI** (\$000)</u>
<u>Counties in Texas</u>			
Potter	100.5	901.871	923.112
Randall	79.5	463.715	837.773
Armstrong	2.0	4.059	18.245
Carson	6.8	20.627	63.001
Castro	10.6	43.187	69.643
Deaf Smith	21.5	86.250	160.470
Hartley	4.3	6.535	38.000
Hutchinson	26.8	111.918	249.355
Moore	17.2	82.137	167.200
Oldham	2.3	5.289	21.596
Swisher	9.6	33.909	68.790
<u>Counties in Iowa</u>			
Des Moines	46.3	243.474	366.404
Henry	19.0	84.087	154.244
Lee	43.3	245.787	328.889
Louisa	12.4	40.325	96.722
<u>Counties in Washington</u>			
Benton	117.6	747.300	1176.908
Franklin	37.3	176.528	375.166

*Source: (S&MM 1982).
 **Effective buying income.

APPENDIX B

PANTEX PLANT

TABLE B-I
MASON & HANGER EMPLOYMENT
(FY-1981 Projections)

1981	2371
1982	2479
1983	2517
1984	2578
1985	2644
1986	2665
1987	2612

TABLE B-II
PLACE OF RESIDENCE - COMMUTING DISTANCE/COUNTY

<u>Place</u>	<u>County</u>	<u>Work Force</u>	<u>Approximate Commuting Distance (1 Way)</u>
Amarillo	Potter	84.9	25
Wildorado	Potter	0.1	50
Bushland	Potter	0.1	40
Borger	Hutchinson	1.0	33
Fritch	Hutchinson	1.1	30
Skellytown	Hutchinson	0.1	35
Stinnett	Hutchinson	0.2	50
Canyon	Randall	1.5	45
Boy's Ranch	Oldham	0.1	60
Claude	Armstrong	2.2	28
Groom	Carson	0.4	50
Panhandle	Carson	6.1	15
White Deer	Carson	0.4	30
Pampa	Gray	0.9	45
Clarendon	Donley	<u>0.9</u>	<u>35</u>
		100.0	25.3 (1-Way Average Miles/Employee)

TABLE B-III

MASON & HANGER/PANTEX
LAND USE AT THE PANTEX SITE

<u>Plant Site</u>	<u>1976</u>
1. No. of buildings	267
2. Approximate floor area	1 284 000 sq ft
3. Roads and parking	
a. Paved roads	26 mi
b. Unpaved roads	20 mi
c. Railroad tracks	24 mi
d. Parking (paved)	23 acres
e. Parking (unpaved)	8 acres
f. Irrigated lawn	7 acres
g. Drainage ditches	35 mi
4. Open space	8000+ acres

NOLAN F. WARD, Chairman
Representing Public
KEN CLAPP, Commissioner
Representing Employers
A. C. SHIRLEY, Commissioner
Representing Workers
ERNE W. TULLIS
Administrator

TEXAS EMPLOYMENT COMMISSION

P. O. Box 1682 - Amarillo, Texas 79189

April 8, 1982



Mr. Don Rapp
H-8, M.S. 490
Los Alamos Lab
Los Alamos, New Mexico 87545

Dear Mr. Rapp:

This is in response to our conversation about the availability of workers for a construction project in the Amarillo area.

It is my feeling that a construction project employing approximately 2700 construction workers, at a peak period, with a build up to that number during a three year period, could be successfully handled by workers in the Amarillo area.

It is possible that some highly skilled workers might have to be brought in from other areas; however this would be a minimum number of people. Also as discussed, the need of approximately 1800 additional workers as a spin-off from the above employed construction workers could also be successfully handled with local applicants.

We appreciate the opportunity to be of service. Please feel free to contact me any time in the future regarding additional information.

Sincerely,

Jeff L. Auld,
Office Manager

JLA/hs

Equal Employment Opportunity Employer

TEXAS EMPLOYMENT COMMISSION

Amarillo SMSA
May 1982

	ANNUAL AVERAGE EMPLOYMENT	ANNUAL AVERAGE UNEMPLOYMENT	PERCENT UNEMPLOYED
1970	62,390	2,680	4.1
1971	64,380	2,780	4.1
1972	68,060	2,890	4.1
1973	67,630	2,080	3.0
1974	69,580	2,500	3.5
1975	73,730	2,750	3.6
1976	77,690	3,150	3.9
1977	79,970	3,290	4.0
1978	82,240	3,120	3.7
1979	84,940	2,960	3.4
1980	82,760	3,640	4.2
1981	84,804	4,000	4.5
1982	90,520*	6,280	6.5**
(Average through March, 1982)			

Estimated average unemployment rate for 1982 is: 5.4.

*Interpolated at 87 600 in a telephone interview with Jeff Auld
(October 1982)

**5.5 was estimated as the correct value to use in this study

NOLAN F. WARD, Chairman
Representing Public

KEN CLAPP, Commissioner
Representing Employers

RICHARD C. MELLADO, Commissioner
Representing Workers

ERNIE W. TULLIS
Administrator

TEXAS EMPLOYMENT COMMISSION

P.O. Box 1682 - Amarillo, Texas 79189-1682

December 3, 1981



Mr. Don Rapp
H-8, MS490
Los Alamos Lab
Los Alamos, NM 87545

Dear Mr. Rapp:

Enclosed please find the information regarding wage rates for this area.
Should you need additional information, please contact us.

We will look forward to you visiting our area in the future and if so,
please visit our office.

Sincerely,

Jeff L. Auld
Office Manager

JLA:nlb

Enclosure

Equal Employment Opportunity Employer

TEXAS EMPLOYMENT COMMISSION

WAGE RATES

AMARILLO, TEXASJULY 1981 to DECEMBER 1981

<u>Job Title</u>	<u>Straight-Time Hourly Rate</u> <u>Range Unless Otherwise Indicated</u>	
	<u>Low</u>	<u>High</u>
Machinist - Craft	\$8.75	\$11.60
Semi-Skilled	6.90	7.20
Machine Operator	4.20	5.25
Maintenance Machinist	8.75	11.60
Engine Lathe Operator	4.40	5.35
Milling Machine Operator	4.25	5.30
Turret Lathe Operator	4.95	6.25
Drill Press Operator	4.25	5.30
Radial Drill Press Operator	5.00	7.75
Tool-and-Die Maker	8.20	8.95
Assembler, Electrical	4.20	4.95
Electric Motor	4.20	4.95
Assembler, Mechanical (Shop Trainee)	4.20	4.95
Electrician	8.85	15.61
Materials Handler	4.10	4.45
Shipper (Warehouse)	4.20	4.65
Drum Filler	4.10	4.35

Wage Rates

Page 3

<u>Job Title</u>	<u>Straight-Time Hourly Rate</u> <u>Range Unless Otherwise Indicated</u>	
	<u>Low</u>	<u>High</u>
Truck Driver		
Single Axle, Light	\$4.00	\$5.15
Single Axle, Heavy	4.65	5.25
Tandem Axle or Semi-Trailer	4.75	5.45
Lowboy	4.25	5.30
Winch	4.50	5.60
Over-the-road (Single Axle)	(Single Cab - 18¢ per mile)	
Tandem Axle (Tandem Axle)	(Sleeper Cab - 22¢ per mile)	
(Tandem 5-Axle)	(Can work up to 70 hours in 8 days)	
Security Guard (Part-time and Full-time)	3.80	5.60
Dispatcher	4.05	5.05
Mechanic, Auto and Truck	6.95	10.55
Heavy Machinery Mechanic (50-60% Commission)	6.95	10.55
Fork Lift Operator	3.95	5.30
Welder - Combination	5.40	8.60
Arc	4.80	5.25
Warehouse (Stock Clerk)	4.20	5.60
Trainee	3.85	4.40
Warehouse, Shipping & Receiving (Supervisor)	6.40	9.65
Millwright (Carpenter)	8.25	14.41
Butcher, Production	5.70	6.80
Meat Wrapper	3.85	6.20
Meat Grinder	3.85	4.40
Unskilled	3.55	4.10
Maintenance Mechanic	6.35	9.20
Maintenance Repairer, Building	4.65	6.95
Accountant, Office Manager, Purchasing	\$1,455/mo	\$2,150/mo
Secretary, Stenographer	4.80	6.40
Programmer, Business	\$1,580/mo	\$2,100/mo

Wage Rates

Page 5

<u>Job Title</u>	<u>Straight-Time Hourly Rate Unless Otherwise Indicated</u>	
	<u>Low</u>	<u>High</u>
Drafter, Mechanical, Electrical	\$5.35	\$7.10
Drafter, Detail	4.70	6.95
Boner, Meat - Skilled	4.45	6.25
Unskilled	3.90	5.05

MINIMUM WAGE: 1-1-81 \$3.35/hr - Hourly rate based on a 40-hour-workweek with time-and-a-half for over 40 hours

For the various classifications of Machinist, Engine Lathe Operator, Milling Machine Operator, Turret Lathe Operator, Radial Drill Operator and Tool-and-Die Maker, one non-union establishment hires at a beginning rate of from \$6.45 per hour up to \$8.25 per hour, depending upon the applicant's training and experience. After the worker has been on the job for a period of time, the maximum pay he may reach is \$9.70 per hour, depending upon his ability and whether he can proficiently operate several machines. In other words, he may spend most of his time operating an engine lathe, for example, but still earn \$9.70 per hour because he can operate other machines also if necessary.

In another establishment in which the craft is unionized, there is no person whose main duty is to operate only one particular type of machine. In this establishment, the Machinist operates milling machines, engine lathes, turret lathes and other machines as required by his job assignment.



3700 S.W. 45TH
AMARILLO, TEXAS 79109
PHONE (806) 353-3565

June 8, 1982

Los Alamos Nat'l Laboratory
Don Rapp
H-8, MS 490
Los Alamos, N.M. 87545

Dear Mr. Rapp,

In reference to our phone conversations of December 3, 1981 and June 7, 1982, concerning the possible plant expansion at the Pantex Plant near Amarillo.

In my opinion, Amarillo could produce the estimated 2,000 construction workers that you referred to over a three year period. I do not feel that it would be necessary for a large number of these workers to move into the Amarillo area since we currently have two large construction projects that will be coming to an end within the next six months. It may be necessary for a few highly skilled technical workers to transfer to Amarillo due to the nature of the Pantex Plant. The Amarillo economy and housing stock will be more than adequate to support the needs of any workers transferring in.

Should you need any additional information, please feel free to call, as we will be glad to help you in any way.

Sincerely,)

Charles Kitten
Executive Director

CK/mac



**Panhandle Regional Planning Commission
Health Systems Agency**

June 18, 1982

Mr. Don Rapp
8730 W. Mountain View Lane
Littleton, Colorado 80125

Dear Mr. Rapp:

Enclosed is the material we discussed by telephone yesterday concerning the Texas Department of Health's recent report on physician manpower in Texas. As you can see, I've included the entire introductory portion to enable you to answer any questions you might have concerning the study's methods and definitions. The last three pages contain physician-to-population ratio information for various subdivisions of the state, including specific information for HSA-1.

Please don't hesitate to contact me if you have further questions.

Sincerely,

Gordon Darrow
Planner/Project Review

Enclosure
2V

GD:ka

TEXAS DEPARTMENT OF HEALTH
MANPOWER SPECIAL REPORTS
PHYSICIANS IN TEXAS
POPULATION TO PHYSICIAN RATIOS BY STATE-HSA
MAY, 1981

HSA	METRO	TOTAL POPULATION	TOTAL PHYSICIANS	POPULATION PER TOTAL PHYSICIAN	DIRECT CR. PHYSICIANS	POP. PER DIRECT CR. PHYSICIAN	DIRECT CR- PRIMARY CR PHYSICIANS	POP. PER DIR-PRIM CR PHYSICIAN
HSA 01	NON METRO	198393	125	1587	114	1740	82	2419
	METRO	177874	305	583	235	757	100	1779
TOTAL		376267	430	875	349	1078	182	2067
HSA 02	NON METRO	156170	93	1679	83	1882	67	2331
	METRO	216778	466	465	318	682	137	1582
TOTAL		372948	559	667	401	930	204	1828
HSA 03	NON METRO	20978	16	1311	13	1614	10	2098
	METRO	498327	671	743	495	1007	216	2307
TOTAL		519305	687	756	508	1022	226	2298
HSA 04	NON METRO	311045	226	1376	196	1587	143	2175
	METRO	361402	530	682	435	831	195	1853
TOTAL		672447	756	889	631	1066	338	1989
HSA 05	NON METRO	197241	175	1127	144	1370	86	2294
	METRO	3151695	5640	559	4068	775	1859	1695
TOTAL		3348936	5815	576	4212	795	1945	1722
HSA 06	NON METRO	347851	267	1303	216	1610	173	2011
	METRO	1052956	1778	592	1282	821	583	1806
TOTAL		1400807	2045	685	1498	935	756	1853
HSA 07	NON METRO	466268	349	1336	284	1642	185	2520

PREPARED BY THE BUREAU OF STATE HEALTH PLANNING AND RESOURCE DEVELOPMENT

TEXAS DEPARTMENT OF HEALTH



Panhandle Regional Planning Commission Health Systems Agency

December 16, 1981

Mr. Don Rapp
H-8, MS 490
Los Alamos National Laboratory
Los Alamos, NM 87545

Dear Mr. Rapp:

The following is provided in response to your recent request for information regarding acute care medical facilities in the Amarillo SMSA (Potter and Randall counties):

1. Attachments 1 through 5 provide specific information concerning each of the SMSA's five hospitals. The largest three of these (St. Anthony's, Northwest Texas, and High Plains Baptist) are considered referral hospitals by reason of bed complement, patient characteristics, staffing and capabilities. A substantial part of their patient caseload is drawn from outside the SMSA.
2. Attachment 6 aggregates certain of the information shown in Attachments 1 through 5 for all five hospitals and for the three referral hospitals, respectively. (This tabulation excludes 134 licensed psychiatric beds operated by the Amarillo Hospital District.) It can be seen that the referral hospitals as a group are operating (as of 1980) at 80 percent occupancy with only 91 percent of their licensed beds actually staffed and operating.
3. Attachment 7 indicates the proportions of each hospital's patients (inpatient admissions) residing in the SMSA, outside the SMSA but within the 25-county HSA-1 region, and outside the region, respectively. The figures shown are percentages.
4. Attachment 8 shows the number of hospital beds per 1,000 population in the SMSA, in the area immediately surrounding (and including) the SMSA, and in the entire region. These ratios were calculated using 1980 census and hospital data.

As may be seen, there appears to be sufficient excess capacity in the SMSA's acute care system to accommodate increases in the population on the magnitude you indicated in our conversation.

If you require further information or clarification, please don't hesitate to contact me.

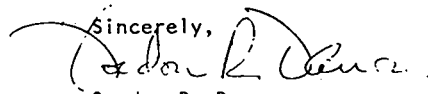
Sincerely,

Gordon R. Darrow
Planner/Project Review

PANHANDLE HEALTH SYSTEMS AGENCY
TEXAS HEALTH SERVICE AREA 1

ACUTE CARE FACILITIES

AMARILLO HOSPITAL DISTRICT, NORTHWEST TEXAS HOSPITAL
AMARILLO, POTTER COUNTY

Year Ending September 30	1978	1979	1980	1981
Ownership	Hospital District	Hospital District	Hospital District	
Licensed Beds	252	252	252	
Operating Beds	252	252	252	
Admissions	11,417	11,529	11,486	
Patient Days	67,082	66,506	64,211	
Average Daily Census	184	182	176	
Avg. Length of Stay	5.9 days	5.8 days	5.6 days	
Occupancy Rate*	73%	72%	70%	

SPECIFIC BED INFORMATION

Bed Type	1978		1979		1980		1981	
	Operating Beds	Occupancy Rate*	Operating Beds	Occupancy Rate*	Operating Beds	Occupancy Rate*	Operating Beds	Occupancy Rate*
Medical/Surgical	166	80%	153	82%	153	85%		
Obstetrical	28	65%	28	71%	28	77%		
Pediatric	34	55%	40	65%	40	34%		
Intensive Care	19	71%	31	35%	31	35%		
Alcohol Detoxification	5	22%						

* Based on number of beds staffed and operating.

100/B3

Source: Hospital Data Questionnaires, Texas Department of Health,
Bureau of Health Planning and Resource Development, 1978, 1979, 1980.

ATTACHMENT 1

Appendix B, Item 6, Page 5

ATTACHMENT 8

PANHANDLE HEALTH SYSTEMS AGENCY

Texas Health Service Area 1

ACUTE CARE FACILITIES

1980 Hospital Beds per 1,000 Population

	<u>Population</u>	<u>Licensed Beds</u>	<u>Licensed Beds Per 1,000</u>	<u>Operating Beds</u>	<u>Operating Beds Per 1,000</u>
Amarillo SMSA	173,699	971	5.6	887	5.1
Amarillo SMSA Plus Contiguous Counties	272,958	1,363	5.0	1,244	4.6
HSA-1	370,174	1,787	4.8	1,668	4.5

Sources: U.S. Bureau of the Census;
Hospital Data Questionnaires, Texas Department of Health, Bureau of
State Health Planning and Resource Development

100A1

ADDRESS AND/OR MESSAGE

ANALYSIS FOR DON RAPP
LOS ALAMOS NATIONAL LABS

THIS MODEL AND PROGRAM HAS BEEN CONSTRUCTED AND IS SUPPORTED BY THE ECONOMICS, WATER REQUIREMENTS AND USES SECTION OF THE TEXAS DEPARTMENT OF WATER RESOURCES. IT IS PRESENTED IN THIS FORM AS A PUBLIC SERVICE. IF YOU HAVE QUESTIONS ABOUT THE MODEL OR ABOUT THIS PROGRAM, PLEASE CONTACT:

AL GLASSCOCK OR
DON DAWKINS
TEXAS DEPARTMENT OF WATER RESOURCES
P.O. BOX 13087
CAPITOL STATION
AUSTIN, TEXAS 78711
TELEPHONE (512) 475-3787

END ONSITE PRINTOUT ON OCTOBER 27, 1982 AT 10:16:50
MINIQUAL#B(1).

TEXAS DEPARTMENT OF WATER RESOURCES
INPUT-OUTPUT SYSTEM FOR ECONOMIC ANALYSIS

"MINIMODEL"

* INDUSTRY: MANUFACTURING
CHANGING FACTOR: CHANGE IN NUMBER OF EMPLOYEES.
VALUE OF CHANGING FACTOR: 2400

THESE ARE THE ESTIMATED YEARLY EFFECTS DUE TO THE
PARAMETERS THAT YOU HAVE ENTERED. RESULTS ARE EXPRESSED IN
FIRST QUARTER 1982 DOLLARS.

VALUE OF CHANGE IN PRODUCTION	-378649652.
CHANGE IN NUMBER OF JOBS:	
CHANGE IN MANUFACTURING	-2400.000
CHANGE IN JOBS ECONOMY WIDE	-10752.000
CHANGE IN WAGES AND SALARY:	
CHANGE IN MANUFACTURING	-54260495.
CHANGE ECONOMY WIDE	-224638448.
CHANGE IN ECONOMIC ACTIVITY ECONOMY WIDE:	-1183280160.
CHANGE IN TAX REVENUES:	
(EXCLUDES TAXES FOR EDUCATION)	
FEDERAL	-47861316.
STATE	-6702099.
LOCAL	-3710767.

IMPACT OF THE ORIGINAL CHANGE ON EACH SEPARATE SECTOR:

	SECTOR	CHANGE IN ECON ACTIVITY	CHANGE IN #OF JOBS	CHANGE IN WAGES
1	AGR., FOR., FSH.	-31049272.	-769.10342	-5501931.
2	MINING	-85953470.	-473.82986	-22837837.
3	CONSTRUCTION	-10602190.	-130.79539	-3430869.
4	MANUFACTURING	-561916080.	-3561.59985	-80522574.
5	TRANSPORTATION	-26505476.	-399.08044	-9467756.
6	COMMUNICATIONS	-5679745.	-124.18390	-1740842.
7	UTILITIES	-34457118.	-174.60842	-4059049.
8	WHOLESALE TRADE	-45437958.	-481.10343	-17339125.
9	RETAIL TRADE	-37486316.	-1645.90338	-14308527.
10	F.I.R.E.	-51496353.	-503.98159	-19754001.
11	EDUCATION	-16281935.	-819.53714	-9259536.
12	SERVICES	-52253652.	-1668.26660	-23618651.

* SEE REFERENCE PAGE, ATTACHED.

TEXAS DEPARTMENT OF WATER RESOURCES
INPUT-OUTPUT SYSTEM FOR ECONOMIC ANALYSIS

"MINIMODEL"

* INDUSTRY: MANUFACTURING
CHANGING FACTOR: DOLLAR VALUE OF CHANGE IN WAGES AND SALARY.
VALUE OF CHANGING FACTOR: 54400000

THESE ARE THE ESTIMATED YEARLY EFFECTS DUE TO THE
PARAMETERS THAT YOU HAVE ENTERED. RESULTS ARE EXPRESSED IN
FIRST QUARTER 1982 DOLLARS.

VALUE OF CHANGE IN PRODUCTION	-379623164.
CHANGE IN NUMBER OF JOBS:	
CHANGE IN MANUFACTURING	-2466.170
CHANGE IN JOBS ECONOMY WIDE	-10779.643
CHANGE IN WAGES AND SALARY:	
CHANGE IN MANUFACTURING	-54400000.
CHANGE ECONOMY WIDE	-225215998.
CHANGE IN ECONOMIC ACTIVITY ECONOMY WIDE:	-1186322384.
CHANGE IN TAX REVENUES:	
(EXCLUDES TAXES FOR EDUCATION)	
FEDERAL	-47984368.
STATE	-6719330.
LOCAL	-3720307.

IMPACT OF THE ORIGINAL CHANGE ON EACH SEPARATE SECTOR:

SECTOR	CHANGE IN ECON ACTIVITY	CHANGE IN #OF JOBS	CHANGE IN WAGES
1 AGR.,FOR.,FSH.	-31129100.	-771.08080	-5516076.
2 MINING	-86174458.	-475.04809	-22896554.
3 CONSTRUCTION	-10629449.	-131.13167	-3439690.
4 MANUFACTURING	-563360768.	-3570.75671	-80729598.
5 TRANSPORTATION	-26573622.	-400.10648	-9492098.
6 COMMUNICATIONS	-5694347.	-124.50318	-1745317.
7 UTILITIES	-34545708.	-175.05734	-4069484.
8 WHOLESALE TRADE	-45554780.	-482.34035	-17383704.
9 RETAIL TRADE	-37582693.	-1650.13499	-14345314.
10 F.I.R.E.	-51628750.	-505.27733	-19804789.
11 EDUCATION	-16323796.	-821.64417	-9283343.
12 SERVICES	-52387997.	-1672.55573	-23679374.

* SEE REFERENCE PAGE, ATTACHED.

APPENDIX C

IOWA ARMY AMMUNITION PLANT

MASON & HANGER - SILAS MASON CO., INC.
IOWA ARMY AMMUNITION PLANT
MIDDLETOWN, IOWA

PERSONNEL AND PAYROLL DATA

I. Distribution of Work Force By Residence

Des Moines County, Iowa	582
Lee County, Iowa	131
Louisa County, Iowa	24
Henry County, Iowa	140
State of Illinois	94
State of Missouri	11
All Others	<u>49</u>
Total (6/30/81)	1031

II. Distribution of Work Force by Function (Exempt & Nonexempt)

	<u>Exempt</u> ⁽¹⁾	<u>Nonexempt</u>
Manufacturing (Production & Quality Assurance)	45	395
Mechanical (Maintenance & Production Support)	20	157
Transportation (Internal)	3	30
Storage & Traffic	8	59
Engineering (Except Production & Quality)	53	29
Development	19	9
Plant Protection	26	59
Utilities	1	30
Administration - (Procurement, Accounting, Personnel & P/R, EDP, Medical, Labor Relations, Services, and Management not included above)	47	41
	<u>222</u>	<u>809</u>
Total Work Force 6/30/81		1031

MASON & HANGER - SILAS MASON CO., INC.
IOWA ARMY AMMUNITION PLANT
MIDDLETOWN, IOWA

PERSONNEL AND PAYROLL DATA (Cont.)

Page 2

- III. Annual P/R (1980) - \$20,217,732.31
- IV. Four area school districts requested employment verification of 56 employees to be used in applying for 1980 - 81 government subsidies.

1) Exempt are paid weekly salary - management



Robert D. Ray, Governor

Colleen Shearer, Director

Iowa Department of Job Service

1000 N. Roosevelt
Burlington, Iowa 52601

Phone: (319) 753-1671

December 8, 1981

Donald Rapp
H-8 MS 490
Los Alamos National Laboratory
Los Alamos, New Mexico 87545

Dear Mr. Rapp,

In our telephone conversation on December 7, 1981, we discussed the potential for available construction workers in Des Moines County, Iowa. In general, we agreed that the local economy would have little trouble accomodating as many as 4,500 construction workers at one time. We felt that the bulk of these workers could be obtained within a reasonable commuting distance to the Burlington labor area and that adequate housing would be available for construction workers moving into the area.

Upon checking surveys returned by local construction firms in a commuting patterns survey taken four years ago, I found that approximately two out of every five construction workers employed locally resided outside of Des Moines County. This commuting ratio was much higher than for any other industry in the county and indicates a real willingness to commute. I feel that we could reasonably expect at least two-thirds of your construction work force of 4,500 to be nonresidents of Des Moines County.

If I can be of any further assistance to you in your research, feel free to contact me at the above address or telephone number.

Sincerely,

Larry J. Holtkamp
Research Economist

LJH/rh
Encl.

/ Job Placement
/ Job Insurance

TABLE 2-1
POPULATION OF UNITED STATES, IOWA, AND REGION, 1940-1980

Year	United States	Iowa	Region XVI
1940	131 669 275	2 538 268	107 256
1950	150 697 361	2 621 073	114 967
1960	179 233 175	2 757 537	117 289
1970	203 211 926	2 825 041	118 774
1980	226 504 825	2 913 387	120 254
Percent change 1940-1950	14.5	3.3	7.2
Percent change 1950-1960	19.0	5.2	2.0
Percent change 1960-1970	13.3	2.4	1.3
Percent change 1970-1980	11.4	3.1	1.2

**BURLINGTON, IOWA LABOR FORCE SUMMARY 1/
IESC 1594-14 (5-81)**

	July 1981	June 6/ 1981	July 1980	NET CHANGE TO:	
				July 1981	July 1980
PLACE OF RESIDENCE					
Resident civilian labor force 2/	19450	19650	20400	-200	-950
Resident unemployed	1380	1340	1560	+40	-180
Percent unemployed	7.1	6.8	7.6	XXX	XXX
Resident total employment 3/	18060	18300	18840	-240	-780
Nonagricultural wage and salary 4/	15470	15720	16130	-250	-660
Other non-agricultural 5/	1410	1390	1500	+20	-90
Agriculture	1180	1190	1210	-10	-30
PLACE OF WORK					
Nonagricultural wage and salary workers (except domestics)	20900	21240	21690	-340	-790
Manufacturing	7010	7180	7650	-170	-640
Durable goods	5960	6130	6660	-170	-700
Furniture and fixtures	690	740	650	-50	+40
Machinery (except electrical)	1880	1980	2370	-100	-490
Electrical machinery	1970	1960	2120	+10	-150
Non-durable goods	1060	1050	990	+10	+70
Food & Kindred	290	290	250	0	+40
Chemical & allied products	300	310	250	-10	+50
Nonmanufacturing	13890	14060	14040	-170	-150
Construction	700	680	870	+20	-170
Transportation, communication & public utilities	1680	1660	1730	+20	-50
Wholesale and retail trade	4900	4940	4930	-40	-30
Wholesale trade	990	990	980	0	+10
Retail trade	3910	3950	3940	-40	-30
Finance, insurance & real estate	700	680	690	+20	+10
Service	3620	3590	3620	+30	0
Government	2300	2510	2210	-210	+90
Persons involved in labor-management disputes	0	0	0	0	0

PLACE OF RESIDENCE CONCEPT Method by which an individual unemployed or employed is counted in the area where he lives regardless of the area where he works. PLACE OF WORK CONCEPT Method by which an employed individual is counted in the area where he works regardless of the area where he lives.

(1) The Burlington Iowa labor area is defined as Des Moines County. Data are based on a March 1980 benchmark. Place of residence data are not CPS adjusted. CPS adjusted data required for allocation of federal funds are available upon request. Data are not adjusted for net migration. (2) Includes unemployed and employed individuals, establishment employment (place of work) data is adjusted for commuting, multiple job holding and unpaid absence patterns. (3) Includes non-agricultural wage and salary for employees, unpaid family & domestic workers & agricultural. (4) Includes all full and part-time wage and salary workers (excluding domestics) who were employed or involved in a labor management dispute during the week including the 12th of the month. (5) Includes nonagricultural self-employed persons, unpaid family workers & domestic workers, private households. (6) Revised to most current information available.



IOWA DEPARTMENT OF JOB SERVICE
1300 N. Des Moines, P.O. Box 609
DES MOINES, IOWA 50301
 OFFICIAL BUSINESS
 PENALTY FOR PRIVATE USE \$300

POSTAGE AND FEES PAID
 U.S. DEPARTMENT OF LABOR
 LAB 449



CITY TO CITY
COMMUTING PATTERNS IN SOUTHEAST IOWA

Prepared by

Larry J. Holtkamp
Manpower Research Economist
IOWA DEPARTMENT OF JOB SERVICE
Research and Analysis Department
1000 North Roosevelt
Burlington, Iowa 52601

Affiliated with

Employment and Training Administration
U.S. Department of Labor

June 1980

TABLE III
CITY TO CITY COMMUTING PATTERNS 1/
Middletown, Iowa

	<u>County Total</u>	<u>Survey Total 2/</u>	<u>Survey Total as Percent of County Total</u>		<u>Survey Total</u>	<u>Survey Total as Percent of County Total</u>
Nonagricultural Wage and Salary Employment (except Domestic) for Des Moines County, Iowa	22,140	13,932	62.9%			
Live and Work in Middletown		52				
Work in Middletown, Live Elsewhere <u>3/</u>				Live in Middletown, Work Elsewhere <u>3/</u>		
Burlington		457		Burlington	101	62.9%
West Burlington		102		West Burlington	18	62.9%
Fort Madison		93				
Mount Pleasant		80				
New London		74				
Danville		56				
West Point		20				
Farmington		17				
Dallas City, ILL.		16				
Wever		16				
Keokuk		14				
Oquawka, ILL.		14				
Salem		12				
Gladstone, ILL.		11				
Donnellson		10				
Fairfield		10				
Mediapolis		10				
Mount Union		10				
Niota, ILL.		10				
Other Iowa Communities		70				
Other Illinois Communities		68				
Missouri Communities		18				

FOOTNOTES

- 1/ Results of commuting patterns survey taken during April 1979 in 17 Southeast Iowa counties (December 1977 in Des Moines County) by the Burlington Job Services of Iowa.
- 2/ Survey results have been refined since their first publication and may not match. These are actual survey results and do not represent totals for the cities.
- 3/ Only communities furnishing 10 or more workers are listed. Out-commuting data is limited to the 17 Iowa counties in this survey. If no state is indicated after the listed city, that city is in Iowa.
- 4/ Results of "Commuting Patterns in Iowa and Illinois" developed jointly by the Job Service of Iowa and the Job Service of Illinois in October 1979.

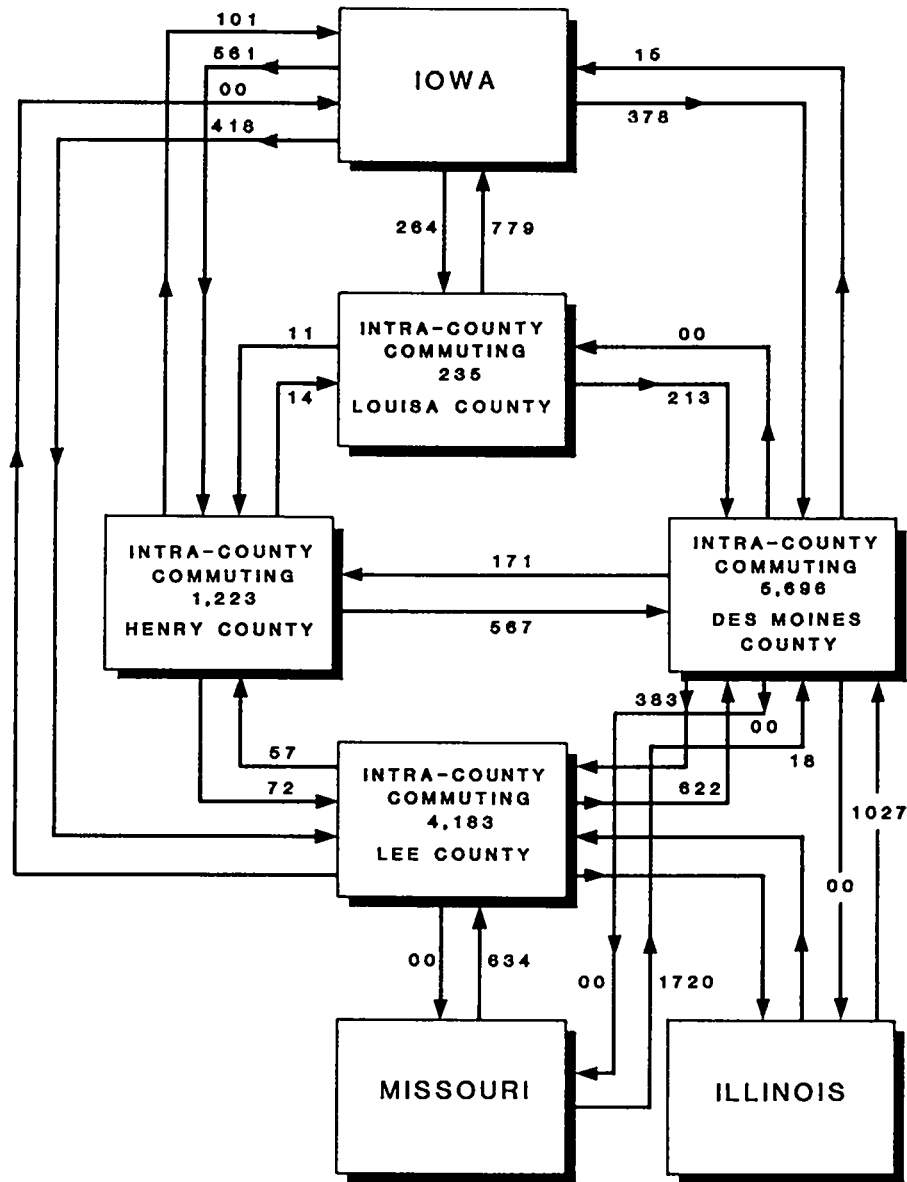

Fig. 3-1. Commuting patterns, Region XVI, 1980

CRAFT CONTRACTS
in the Burlington, Iowa labor area

This information is current as of December 8, 1981, to the best of my knowledge. It was obtained from the office of Don Crist, Iron Workers Local 577 business representative and president of the Building Trades Association in Burlington. Fringe benefits are not included in these wage rates. This is not an all inclusive list.

	<u>Current Wage Rate</u>	<u>Contract Expires</u>
Boilermakers	\$ 14.97	7/19/82
Bricklayers	14.18	4/30/82
Carpenter	14.35	4/30/84*
Carpenter-Welder	14.65	4/30/84*
Carpet Layer	14.95	INA
Cement Finisher	16.15	4/30/84*
Electrician	14.10	4/30/82
Iron Workers	15.05	4/30/82
Laborers, General	12.50	INA
Millwright-Welder	15.05	4/30/84*
Painters		4/30/82
Brush & Paper Hanger	13.00	
Dry Wall Finisher	13.00	
Roller	13.10	
Sign Writer	12.25	
Spray & Sand Blaster	14.00	
Structural Steel over 25 ft.	13.70	
Plumbers & Pipefitters	15.15	4/30/82
Power Equipment Operators	14.80	4/30/82
Roofers	13.13	4/30/83*
Sheet Metal Workers	14.45	5/31/84*

* subject to annual wage reopeners.

INA: Information Not Available

Larry J. Holtkamp
Research Economist
Job Service of Iowa
1000 N. Roosevelt
Burlington, Iowa 52601

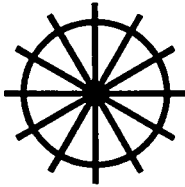

City of Burlington, Iowa

PROGRESSIVE GOVERNMENT ON THE MISSISSIPPI

BURLINGTON, IOWA 52601

September 28, 1981

Donald Rapp
S 3 Mail Stop
MS 603
Los Alamos Laboratory
Los Alamos, New Mexico 87545

BURLINGTON, IOWA

In response to your phone request to Mayor Roy F. Uffelman, I have compiled the following information for your consideration.

Housing

Burlington is the major city in the area with a general population of 30,000. The city has a larger supply of available housing, when compared to similar size cities. Housing characteristics in the Burlington area are as follows:

1. The city lost 14% of its population between 1970 and 1980; however, the loss in housing units was only 3½%.
2. The 1980 Census of Housing shows a vacancy rate of 6½% (732 units). There are currently 284 single family homes and 31 multiple family structures listed "for sale" with Burlington realtors today. Twenty percent (20%) of these listings are vacant and available for immediate occupancy.
3. Most of Burlington's housing stock is large older homes; 79% built before 1950 with a majority actually built before 1900. Many are under utilized as single family dwellings with today's small family life styles.
4. Under utilized housing stock is also apparent in the high percentage of one person (23%) and two person (29%) households. Most of these small households are composed of elderly persons living in larger homes. While a few of Burlington's older homes have been converted



Mr. Rapp
September 28, 1981
Page Two

into apartments, most are still functioning as single family units. It appears a significant number of additional dwelling units could be made available without an increase in new construction.

5. Moderate priced housing in Burlington has been enhanced by an active housing rehabilitation program. Code enforcement and demolition of blighted structures have been actively pursued during the past ten (10) years. Quality moderate priced housing in good residential neighborhoods have resulted from the policies and actions of former city councils.
6. The belief that a city can assist industry by upgrading and maintaining existing housing stock is evident in the actions and programs of the present city council. Burlington is undertaking a three year federal program in the Flint Hills Manor to rehabilitate housing and upgrade community facilities. The 145 acre Manor area was built in the 1940's to house the large influx of defense workers at the Iowa Army Ammunition Plant. It contains 743 dwelling units consisting of single, duplex, four-plex, and six-plex houses. The current estimated vacancy rate is 15% (110 units).
7. The ability of Burlington to expand its housing stock without new construction is a significant asset in the community. Examples would include the following:
 - a. Hotel Burlington contained 125 transient rooms and 41 efficiency apartments in 1978. While the hotel has been closed for the past two years, the present owner has expressed plans to renovate the building and develop 100 apartments.
 - b. YMCA and YWCA are both large three story buildings located in downtown Burlington. When in operation the Y's provided upto 50 rooms for transient living. A wide range of recreational facilities are available to future residents including two gymnasiums and two swimming pools.
8. The Burlington community has eleven mobile home parks containing 939 spaces. It is estimated that 10% of these spaces are not occupied and would be available for locating additional units to be placed upon.

Law Enforcement

1. Des Moines County Sheriff
 - a. Personnel
 - 1 Sheriff
 - 13 Deputies
 - 16 Support and Clerical
 - 30 Total

Mr. Rapp
September 28, 1981
Page Three

b. Vehicles

10 Automobiles fully equipped including radios
1 - "6 X 6" overland 10 wheel vehicle

2. Burlington Police Department

a. Personnel

2 Administrative
8 Officers
5 Detectives
22 Patrolmen
14 Support and Clerical
51 Total

b. Vehicles

9 Marked automobiles fully equipped
4 Unmarked automobiles fully equipped

Fire and Safety

1. Burlington Fire Department

a. Personnel

10 Officers (2 Administrative)
40 Firefighters
1 Secretary
51 Total

b. Vehicles

1980 Pumper - 1500 gallons
1973 Pumper - 1000 gallons
1971 Pumper - 1000 gallons
1964 Pumper - 1000 gallons
1952 Pumper - 1000 gallons
1978 Pumper and Rescue - 1000 gallons
1977 Aerial Ladder
1978 Crash Fire Rescue Pumper - 1000 gallons (airport)
1974 Crash Fire Rescue Chemical Unit (airport)
2 Station Wagons
1 Pickup

Mr. Rapp
September 28, 1981
Page Four

c. Ambulances

4 fully equipped vehicles

(The City-County Emergency Ambulance Service has 4 paramedics, 4 EMT II's, and 1 EMT manning these units.)

Labor Force

Des Moines County employment decreased dramatically during 1980, after three years of steady growth. Durable goods manufacturing accounted for a major portion of the worker loss. High interest rates and record levels of inflation decreased the demand for products manufactured locally.

Manufacturing has been losing workers piecemeal over the past year and shows the largest annual reduction of workers of any industry. During second quarter FY 1981 there were 7,039 individual applicants available during period in over 1200 different occupations. This yields a supply/demand ratio of 9.7 or for every opening available locally, there are ten applicants. A substantial supply of material handlers exist in the local labor force with no projected need. The eight highest occupations in terms of applications available during the quarter are:

Material Handler	377
Administrative Clerk	244
Assembler, Production	187
Industrial Truck Operator	124
Construction Worker I	114
Welder, Arc.	105
Cashier - Checker	100
Tractor-Trailer-Truck Driver	98

Des Moines County is currently exporting more workers than it did in 1970, especially to Lee County and Henry County where manufacturing employment has made significant gains.

As employment in Des Moines County gradually declined during 1980, unemployment increased to record levels. In August 1980, many local manufacturers extended their normal two-week shut-down, thereby forcing the local jobless rate up to 9.8%. Although local rates declined of August, the year ended with 6.6% unemployment and has since jumped to 7.5% for January 1981. Female unemployment is expected to more than triple male unemployment.

Mr. Rapp
September 28, 1981
Page Five

Population and labor force projections indicate that female participation in the local labor force will continue to grow rapidly in the immediate future. Since most of these female workers will be new or re-entrants into the labor force, they may lack the basic qualifications required by local employers. Many will also need to have existing skills updated, since a high percentage of the long term unemployed are female. The female worker should be the primary target for any training program of local workers.

The projected total labor force for Des Moines County in 1982 is 19,869, down 507 since the 1970 census. Even though the total labor force is projected to decrease, female participation has increased from 40.9% in 1970 to a projected 48.1% in 1982. The number of females in the labor force is projected to show a twelve year increase of 1,222 workers, while male participation declines by 1,729.

Since the overall make-up of the local economy has not changes that much since 1970, this indicates that more females are working in traditionally male dominated occupations. A primary reason for this change-over has been an increase emphasis by local employers in affirmative action programs. One of the major factors behind increasing female participation in the labor force is inflation. As inflation decreases the buying power of the average worker's takehome pay, families find it necessary to supplement their income, which often forces the wife into the labor market. Female participation in the labor force is expected to continue to rise locally as new job opportunities open up.

Attachments

I've also included copies of various tables listing housing and labor force data for your reference. The maps illustrate the general land use, public facilities and major transportation facilities in the ten kilometers surrounding the Iowa Army Ammunition Plant. If either Mayor Uffelmann or I may be of further assistance, please contact us.

KENNETH L. VELHARTICKY - PLANNING DIRECTOR

tw

enclosures

MAJOR PUBLIC FACILITIES

(within 10 kilometers of Iowa Army Ammunition Plant)

Governmental/Public Safety Facilities

44. Burlington City Hall
45. Burlington Central Fire Station/Police Station
46. Burlington Branch Fire Station No. 1
47. Burlington Branch Fire Station No. 2
48. Burlington Branch Fire Station No. 3
49. Burlington Post Office
50. Federal Building - Burlington
51. Des Moines County Courthouse
52. Des Moines County Home
53. Hope Haven Complex
54. Danville City Hall
55. Danville Fire Station
56. Danville Community Building
57. Danville Post Office
61. Middletown Post Office
62. West Burlington City Hall/Police Station
63. West Burlington Fire Station
64. West Burlington Post Office
93. Denmark Fire Station
95. Wever Fire Station

Cultural Facilities

12. Burlington Memorial Auditorium
13. Burlington Public Library
14. Des Moines County Historical Museum
17. Snake Alley

Major Health Care

3. Klein Memorial Hospital
4. Burlington Memorial Hospital

Educational Facilities

29. Black Hawk Elementary (grades K-5)
30. Central Avenue Elementary (grades K-3)
31. Corse Elementary (grades K-5)
32. Flint Hills Elementary (grades K-5)
33. Grimes Elementary (grades K-5)
34. Lincoln (Special Education)
35. North Hill Elementary (grades K-5)
36. Perkins Elementary (grades K-5)

-2-

Educational Facilities (continued)

37. Prospect Elementary (grades K-5)
38. Salter Elementary (grades K-5)
39. Sunnyside Elementary (grades K-5)
40. Washington Elementary (grades K-5)
41. Middletown Elementary (grades K-5)
42. Apollo Central (grades 6-9)
43. James Madison Middle (grades 6-8)
44. Oak Street Middle (grades 6-8)
45. Horace Mann Middle (grades 6-8)
46. Burlington Community High School (grades 10-12)
47. St. John (grades 1-8)
48. St. Paul (grades 1-8)
49. Notre Dame High (grades 9-12)
50. Danville Elementary/Junior High (grades K-8)
51. Danville Community High School (grades 9-12)
58. West Burlington Elementary (grades K-4)
59. West Burlington Middle (grades 5-8)
60. West Burlington High (grades 9-12)
61. St. Mary's Elementary (grades 1-8)
70. Denmark Elementary (grades K-6)

Colleges and Universities

94. Southeastern Iowa Community College - West Burlington Campus

RECENT HOUSING ACTIVITIES

Maple Hills Redevelopment Project

75 units - constructed Maple Hills Apartments
11 units - developed in scattered locations in the project area
3 units - homestead development
150 units (est) - rehabilitation grants/loans

Multiple Dwelling Projects

226 units - Fairway Apartment Complex
60 units - Orchard Meadow Estates

Approved Subdivisions

43 lots - Hiawatha Estates
28 lots - Ridge Top
22 lots - Orchard Meadow Estates

22 parcels available for sale and develop that is presently owned
by the City

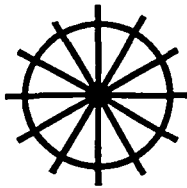

City of Burlington, Iowa

PROGRESSIVE GOVERNMENT ON THE MISSISSIPPI

BURLINGTON, IOWA 52601

June 4, 1981

Mr. Craig Woodworth
Southeast Iowa Regional Planning
508 N. Main
Burlington, Iowa 52601

Dear Mr. Woodworth:

Per your phone request of June 1 enclosed please find the following requested information:

1. Burlington Fire Department Personnel:

Fire Chief, Assistant Chief,
Deputy Chief, Captain-Inspector (Fire Prevention Bureau)

Three Captains -- Three Lieutenants -- 40 Firefighters
These men work a 24 hour shift -- 3 shifts

2. Fire Stations:

Three permanent manned stations
One Airport CFR Station (Crash Fire Rescue Service) -- one man
is dispatched to cover all incoming and outgoing MVA/Ozark Flights

3. Services Provided:

City County Emergency Ambulance Service - Four ambulance response
units. At this time we have 4 Paramedics, 4 EMT II's and 1 EMT I
manning these units. (These men are included in the 40 FF figure)

We have an Emergency One Rescue Pumper that aids the ambulance in
Personal Injury (Car Accidents, CPR) calls.

Regular fire fighting services.

4. Vehicle Information:

Central Station - 5th & Valley houses the following response units:

- Engine 1 - Hendrickson Telesqurt (Pumper, Ladder, Watertower)
- Engine 4 - American LaFrance (Pumper)
- Squad 15 - Emergency One (Pumper/Rescue)
- Truck 14 - American LaFrance (Aerial Ladder)
- 4 Ambulance Response Units



Page Two
June 4, 1981

- Station 2 - Osborn Street houses the following response unit:
Engine 2 - American LaFrance (Pumper)
- Station 3 - Summer Street houses the following response unit:
Engine 3 - American LaFrance (Pumper)
- Airport CFR (Crash, Fire, Rescue) Station - Municipal Airport
houses the following response units:
CFR I -- Oshkosh (Pumper)
CFR II - Chevrolet 4-wheel drive (Chemical Unit)

I believe I have covered all the requested information. If not, please advise.

Thank you for your interest in the Burlington Fire Department.

Cordially,

Linda M. Schulte, Secretary



TABLE C-I

CURRENT LEVEL OF DEBT FOR MAJOR CITIES, 1981

<u>City</u>	<u>Bond Rating</u>	<u>Maximum Indebtedness</u>	<u>Current Indebtedness</u>	<u>Debt-Service (annual)</u>
Burlington	Aa	\$17,575,932	\$9,803,000	\$603,109
Fort Madison	Aa	11,311,452	7,005,316	408,995
Keokuk	A-1	8,000,000	2,500,000	300,000
Mt. Pleasant	-	-	1,720,000	126,000

TABLE C-II

EDUCATION FACILITIES - MAJOR CITIES, 1981

<u>City</u>	<u>Number of Schools</u>		<u>Number of Students</u>		<u>Number of Teachers</u>	
	<u>Public</u>	<u>Private</u>	<u>Public</u>	<u>Private</u>	<u>Public</u>	<u>Private</u>
Burlington	16	3	6 528	515	403	30
Fort Madison	6	3	3 083	538	202	33
Keokuk	8	2	2 666	-	169	-
Mt. Pleasant	9	0	2 144	0	141	0
W. Burlington	3	0	578	0	39	0

1: Total of Elementary, Middle, and High School.

TABLE C-III

HOSPITAL FACILITIES - MAJOR CITIES, 1981

<u>City</u>	<u>Total Beds</u>	<u>Intensive Care</u>	<u>No. of Doctors</u>	<u>Total Patients Served</u>			<u>Occup. Rate</u>
				<u>Inpatient</u>	<u>Outpatient</u>	<u>ER</u>	
Burlington	395	12	65	12 663	136 400	19 391	80
Fort Madison	111	4	20	3 484	5 141	5 302	45
Keokuk	120	8	23	5 000	(22 000)	-	-
Mt. Pleasant	88	3	14	2 112	12 986	953	42

APPENDIX D

HANFORD SITE

JOHN SPELLMAN
Governor



NORWARD J. BROOKS
Commissioner

STATE OF WASHINGTON
EMPLOYMENT SECURITY DEPARTMENT
6515 W. Clearwater, P.O. Box 7205
Kennewick, Washington 99336

April 7, 1982

Donald Rapp
H-8 US 490
Los Alamos National Laboratory
Los Alamos, New Mexico 87545

Dear Mr. Rapp:

Enclosed please find the following:

1. Grant County's P.U.D. power projects description for Priest Rapids and Wanapum dams. These projects lie northwest of the Tri-Cities along the Columbia River.
2. Work force projections for WPPSS and Puget Sound Power and Light Company at Hanford.
3. Construction employment estimates for anticipated Highway projects in the Tri-Cities.

In addition, the Research and Statistics Branch of the Washington State Employment Security Department current projection of Labor Force data for the Tri-Cities S.M.S.A. is as follows:

	FY - 1981	FY - 1982	FY - 1983
Resident Civilian Labor Force	82,340	82,530	80,030
Employment	75,020	73,010	71,670
Unemployment	7,320	9,520	8,360
Percent of Labor Force	8.9%	11.5%	10.4%

These projections are predicated on the assumptions:

1. WPPSS generated employment peaked on June 1981 and should continue to decline significantly over the forecast period.
2. D.O.E. generated employment is expected to be less in FY'82 over FY'81 and less in FY'83 than in FY'82.
3. Off Hanford employment base is expected to remain relatively flat in FY'82 and FY'83.

Sincerely,



Dean Schau
Dean Schau, Labor Management Economist



PUBLIC UTILITY DISTRICT OF GRANT COUNTY

P.O. BOX 878 • EPHRATA, WASHINGTON 98823 • 509/754-3541

February 23, 1982

Mr. Dean Schau
Department of Employment Security
P. O. Box 7205
Kennewick, WA. 99336

Dear Mr. Schau:

Enclosed are some basic information sheets on Grant County PUD and anticipated construction work ahead for this utility.

Of particular interest to you would be the excerpts from our Environmental Impact Statement that deal with socio-economic resources and impacts. These pages detail the size and type of work force needed and the areas that such workmen would likely be drawn from.

No date has been set for the start of expansion on the Priest Rapids Project. Our Commissioners will not make a decision to proceed on the 4-year, \$640 million expansion project until the following questions have been satisfactorily resolved:

- 1) Power sales contracts with current power purchasers who are entitled to their same percentage shares of the new power production. (63.5 percent of the output)
- 2) Sale of Grant PUD's share of the new power output (36.5 percent) until actually needed in Grant County.
- 3) Resolution of minimum instream flow requirements for fish runs below Priest Rapids Dam.
- 4) Federal Energy Regulatory Commission licensing approval.
- 5) Effects of Initiative 394.

If all these issues could be quickly resolved, it may be possible to proceed in mid-1983.

Final contract details are being resolved currently with the Columbia Basin irrigation districts on the \$22 million Quincy Chute Low-head Hydroelectric Project. We hope to accomplish that construction primarily through 1983.

Please contact me at any time for an update on our situation.

Very truly yours,

Gary M. Garnant
Public Affairs Officer

GMG:kfw
Enclosures

EXPANSION OF PRIEST RAPIDS PROJECT
AMENDMENT TO ENVIRONMENTAL REPORT (EXHIBIT W)

SOCIO-ECONOMIC RESOURCES

7.2

Construction Personnel and Supervisory Engineers

The number of construction personnel and supervisory engineers to be employed at the project site was estimated, based upon the construction activities described in Section 5 and the schedule shown on Figure 5-12 of the Environmental Report.

An evaluation of the work was performed considering size, complexity and methods of construction, the number of shifts required for each phase, and the size of crews to be employed for the completion of each component. Climatic conditions and environmental constraints were also considered, as well as limitations imposed by site conditions. Finally, the manpower required was developed per craft for each increment of time. Table 1-1 reflects the estimated average number of personnel for each month. The total personnel requirement over the whole construction period amounts to 23,880 manmonths of construction personnel and 1,200 manmonths of supervisory engineers.

**Work Force History
and Projected Requirements On-Site
for WPPSS 1 and 2 and S/HNP**

<u>Year</u>	<u>WPPSS Work Force</u>	<u>S/HNP Work Force</u>
1977	2,482	
1978	5,915	
1979	7,928	
1980	6,700	
1981	10,456 ^a	
1982	9,000	
1983	5,450	571
1984	2,420+50 ^b	1,257
1985	1,140+50	2,242
1986	620+100	3,373
1987	620+100	4,287
1988	620+100	4,617
1989	620+100	4,108
1990	620+100	2,717
1991	620+100	1,677
1992	620+100	601
1993	620+100	295+50 ^b
1994	620+100	295+50
1995	620+100	295+50
1996	620+100	295+50
1997	620+100	295+50
1998	620+100	295+50
1999	620+100	295+50
2000	620+100	295+50

^a WPPSS workforce figures from 1977 to 1981 come from WPPSS printouts.

^b Estimated average annual refueling personnel required.

Source: Workforce History, WPPSS, February 1982; Frank Clemente, December 1981; URS Company, December 1981; Puget Sound Power and Light Company, 1981.

U.S. DEPARTMENT OF LABOR
BUREAU OF LABOR STATISTICS
MONTHLY REPORT ON LABOR FORCE AND UNEMPLOYMENT

08 STATE: 53-- WASHINGTON DATE SUBMITTED: 3/11/82
(1-2)

: SM6740008----- RICHLAND-KENNEWICK-PASCO
(4-12)

	YEAR/MONTH (20-24)	CIVILIAN LABOR FORCE (26-34)	EMPLOYMENT (36-44)	UNEMPLOYMENT NUMBER (46-54)	UNEMPLOYMENT RATE (56-64)
JAN	81 01	80972	73547	7425	9.2
FEB	81 02	82414	75207	7207	8.7
MAR	81 03	83187	76508	6679	8.0
APR	81 04	83028	77209	5819	7.0
MAY	81 05	83547	77837	5710	6.8
JUN	81 06	84951	78832	6119	7.2
JUL	81 07	83987	76305	7682	9.1
AUG	81 08	83262	75629	7633	9.2
SEP	81 09	83271	76070	7201	8.6
OCT	81 10	84527	76089	8438	10.0
NOV	81 11	82943	73937	9006	10.9
DEC	81 12	82955	72589	10366	12.5
N. AVG.	81	83253	75813	7440	8.9

REFERENCES

- Amarillo 1979: "Amarillo, Texas--Proud New City of the Old West," Amarillo Board of City Development (1979).
- Amarillo 1980: "Amarillo Community Profile," Amarillo Chamber of Commerce, Amarillo, Texas (1980).
- Berger 1981: Berger & Associates, Cost Consultants, The 1981 Berger Building and Design Cost File (Van Nostrand Reinhold Co., New York, 1981).
- BFCMS: Benton-Franklin County Medical Society Register of Doctors.
- DRI-BBC 1982: "Socioeconomic Impact of Power Plants: Review of State of Art in Twelve Case Studies," Denver Research Institute and Browne, Bortz, and Caddington for the Electric Power Research Institute (February 1982).
- Gilmore 1975: John S. Gilmore and Mary K. Duff, Boomtown Growth Management: A Case Study of Rock Springs-Green River, Wyoming (Colorado Westview Press, Boulder, 1975), pp. 29-36.
- IJS 1981C: "Burlington, Iowa, Labor Force Summary," Iowa Job Service report IESC 1594-14 (May 1981).
- LATA 1982: J. M. Greenwood and T. M. Rudell, "1990 Population Forecasts for the Pantex, Burlington, and Hanford Areas," Los Alamos Technical Associates (February 1982).
- OWRC 1975: "Construction Worker Profile," Old West Regional Commission, Billings, Montana (December 1975).
- PRPC 1981: Gordon R. Darrow, Panhandle Regional Planning Commission Health Systems Agency, "Acute care medical facilities in Amarillo SMSA," letter to Don Rapp (December 1981).
- Purtymun 1982B: W. D. Purtymun, N. M. Becker, and M. Maes, "Supplementary Documentation for an Environmental Impact Statement Regarding the Pantex Plant: Geophydrologic Investigations," Los Alamos National Laboratory report LA-9445-PNTX-H (1982).
- Rapp 1974: D. A. Rapp, "Impacts--An Assessment of the Impact of Oil Shale Development--Vol. 5 Population Analysis," Office of the Governor, State of Colorado (December 1974).
- Rapp 1980: D. A. Rapp, "Uranium Mining and Milling Work Force Characteristics in The Western US," Los Alamos Scientific Laboratory report LA-8656-MS (December 1980).

- S&MM 1982: "1982 Survey of Buying Power," Sales and Marketing Management, New York (July 26, 1982).
- Schnurr 1982B: N. M. Schnurr, "Supplementary Documentation for an Environmental Impact Statement Regarding the Pantex Plant: Description of Facilities and Estimation of Resource Requirements," Los Alamos National Laboratory report LA-9445-PNTX-L (1982).
- SEAM 1978: "Social and Economic Assessment Model," Argonne National Laboratory Technical Memorandum (April 1978).
- SIRPC 1978: "Development Plan," Southeast Iowa Area XVI Regional Planning Commission (with certain updated information), Chapter 3 (January 1981).
- Smith 1981: W. G. Smith, "Amarillo Tackles Full Employment Problems," Texas Business, p. 55 (January 1981).
- TCCC 1981B: "Tri-City Facts," Tri-Cities Chamber of Commerce, Washington (1981).
- TCRERC 1981: "Tri-Cities Real Estate Research Report," Tri-Cities Real Estate Research Committee report, Vol. 4, No. 1 (1981).
- USCC 1973: "What New Jobs Mean to a Community," United States Chamber of Commerce (1973).
- USDOD 1979: "Environmental Assessment for the Burlington, Iowa, Facility," US Army (December 1979).
- USDOE 1980A: "Environmental Aspects of Long-Term Management Alternatives for High-Level Defense Waste at the Hanford Site," USDOE report RHO-LD-140 (October 1980).
- USDOE 1980B: "Draft EIS--Operation of PUREX and Uranium Oxide Plant Facilities," USDOE Draft Working Papers Document 3 (July 1981).
- WJS 1980: "Annual Planning Report 1980," Washington State Employment Security Department (July 1980).
- WJS 1981A: "Annual Planning Report 1981," Washington State Employment Security Department (July 1981).
- WJS 1981B: "Labor Area Summary," Washington State Employment Security Department (June 1981).
- WPPSS 1979: "Socioeconomic Impact Study WNP 1 and 4, Vol. 4: Final Report," Washington Public Power Supply System (May 1979).

WPPSS 1980: "Projections and Distribution of Population with a 50-Mile Radius of WPPSS Nuclear Projects Numbers 1, 2, and 4," Washington Public Power Supply System (October 1980).

Printed in the United States of America
 Available from
 National Technical Information Service
 US Department of Commerce
 5285 Port Royal Road
 Springfield, VA 22161

Microfiche (A01)

Page Range	NTIS Price Code	Page Range	NTIS Price Code	Page Range	NTIS Price Code	Page Range	NTIS Price Code
001-025	A02	151-175	A08	301-325	A14	451-475	A20
026-050	A03	176-200	A09	326-350	A15	476-500	A21
051-075	A04	201-225	A10	351-375	A16	501-525	A22
076-100	A05	226-250	A11	376-400	A17	526-550	A23
101-125	A06	251-275	A12	401-425	A18	551-575	A24
126-150	A07	276-300	A13	426-450	A19	576-600	A25
						601-up*	A99

*Contact NTIS for a price quote.

Los Alamos